

DN 15-100

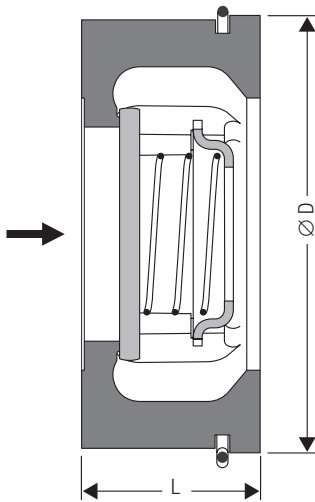

DISCO Non-Return Valves

RK 76 for Flanges PN 6/10/16/25/40, DN 15-100 ASME Class 150/300

Description

Wafer-type non-return (check) valve for sandwiching between flanges. Valve with spring for installation in any position. Without spring only for vertical lines with upward flow. Self-centering valve body ensures accurate installation. Application for liquids, gases and vapours. Please observe the classification according to the Pressure Equipment Directive (PED).

Pressure / Temperature Rating

RK 76 [°C]	DIN, EN, ASME B16.5, Class 300					Design
	-10	20	100	200	300	
DN 15 – 100 [bar] g	49.6	49.6	42.3	35.8	31.6	metal-to-metal (standard)
	49.6	49.6	42.3	35.8	31.6	metal-to-metal with Nimonic® springs

Valve disc gasket	t _{min} [°C]	t _{max} [°C]	Application	Leakage rate
Metal-to-metal RK 76, DN 15-100	-10	300	Liquids, gases, vapours	DIN EN 12266, Class D
PTFE*)	-190	250	Corrosive fluids	DIN EN 12266, Class D
EPDM*)	-40	150	Water, condensate, vapours	DIN EN 12266, Class A
FPM*)	-25	200	Mineral oils, gases, air	DIN EN 12266, Class A

For additional information on chemical resistance go to www.gestra.de and click on "Technical Support" and then on "Chemical Resistance".

*) Observe pressure/temperature limits of the equipment!

End Connections

DIN	ASME	BS 10 ¹⁾	JIS
EN 1092-1 PN 10/16/25/40	B 16.1 Class 125 FF B 16.5 Class 150/300 RF	Table D, E, F, H, J	B2238 10K

¹⁾ Table D, E, DN 65, DN 80: Select DN one size smaller.

Dimensions

Valve size	[mm]	15	20	25	32	40	50	65	80	100
	[Inch]	½	¾	1	1¼	1½	2	2½	3	4
Face-to-face dimensions	[mm] L ²⁾	16	19	22	28	31.5	40	46	50	60
Ø D	PN 6-40	45	55	65	75	85	98	118	134	154
Weight	[kg]	0.18	0.30	0.45	0.70	0.90	1.50	2.10	3.40	5.20

²⁾ Short overall length according to EN 558-1, series 49 (≙ DIN 3202-3, series K4)

Materials

DN 15 – 100		DIN/EN	ASTM	Category
Body, seat and guide ribs	RK 76	1.4107	ASTM A217 CA15	Chromium steel
Valve disc, spring retainer		1.4571	Austenitic stainless steel	
Spring			Austenitic stainless steel	
Spiral centering ring		1.4310	Chromium steel	

DISCO Non-Return Valves

RK 76

for Flanges PN 6/10/16/25/40, DN 15-100, ASME Class 150/300

Opening Pressures

Differential pressures at zero volume flowrate

DN	Opening pressures [mbar]			
	Direction of flow in valve			
	without spring ↑	with springs		
	↑	→	↘	↓
15	2.5	10	7.5	5
20	2.5	10	7.5	5
25	2.5	10	7.5	5
32	3.5	12	8.5	5
40	4.0	13	9	5
50	4.5	14	9.5	5
65	5.0	15	10	5
80	5.5	16	10.5	5
100	6.5	18	11.5	5

On request at extra charge, special springs for opening pressures:

Between 5 and 1000 mbar for DN 15 – 50 mm,
between 5 and 700 mbar for DN 65 and 80.

Enquiry Specification

GESTRA DISCO Non-return valve type RK 76, wafer design with extremely short overall length to EN 558-1, table 11, series 49. Body with spiral centering ring.

Broad sealing surfaces at body inlet and outlet. Designed in accordance with PED 97/28/EC.

Type: RK 76

Connection: Wafer design for sandwiching between flanges

Nominal size: DN 15 / DN 20 / DN 25 / DN 32 / DN 40 / DN 50 / DN 65 / DN 80 / DN 100

Pressure: PN 6 / PN 10 / PN 16 / PN 25 / PN 40 / CL 125 FF / CL 150 / CL 300 RF

Seating surface: metal-to-metal / PTFE / EPDM / FPM

Certificates: Test certificate to EN 10204, 2.1 / 2.2 / 3.1.

Please note:

The selected non-return valve must ensure that the minimum volume flowrate keeps the valve disk in the open position (see Pressure Drop Chart / stable range). Valve construction is very robust, but they are not recommended for use on compressors or where pulsating flow exists. If in doubt please consult us and we will carry out the pressure drop calculation and select a suitable valve.

Supply in accordance with our general terms of business.

Pressure Drop Chart

The curves given in the chart are valid for water at 20 °C. To read the pressure drop for other fluids the equivalent water volume flowrate \dot{V}_w must be calculated and used in the graph.

The values indicated in the chart are applicable for spring-assisted valves with horizontal flow and to valves without spring installed in vertical pipes with upward flow.

$$\dot{V}_w = \dot{V} \cdot \sqrt{\frac{\rho}{1000}}$$

\dot{V}_w = Equivalent water volume flow in l/s or m³/h

ρ = Density of fluid (operating condition) in kg/m³

\dot{V} = Volume of fluid operating condition) in [l/s] or [m³/h]

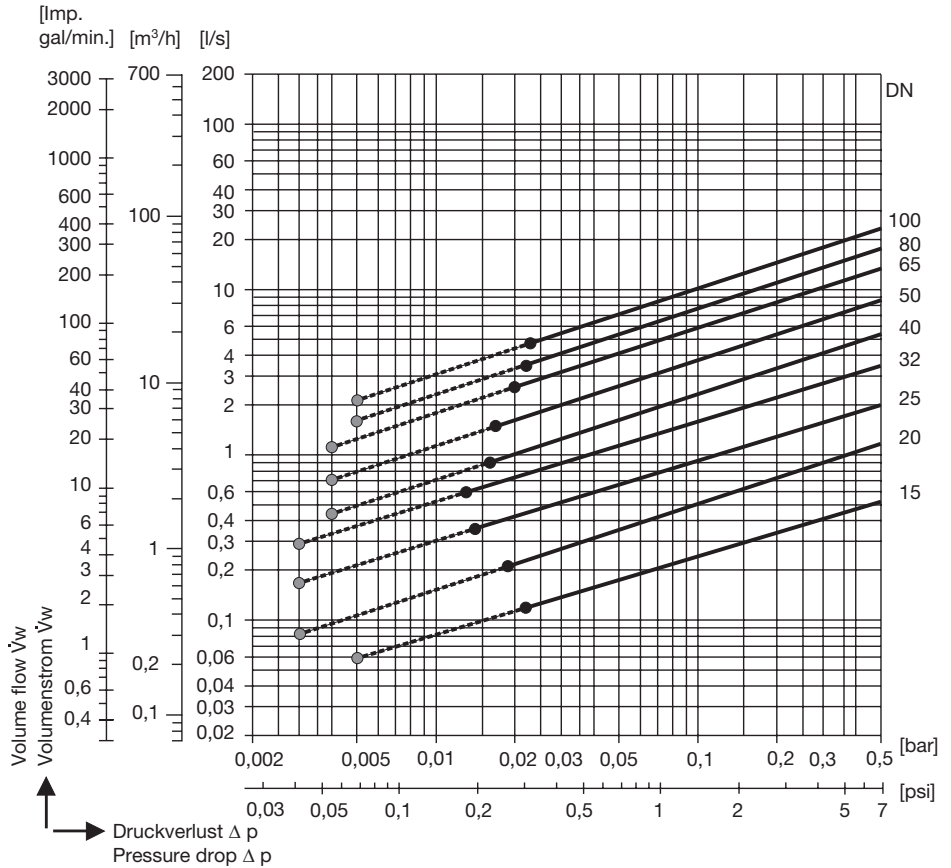

When ordering please state:

Fluid, flowrate, service pressure and temperature, standard of pipe flange.

The following test certificates can be issued on request, at extra cost:

In accordance with EN 10204-2.1, -2.2 and 3.1

All inspection requirements have to be stated with the order. After supply of the equipment certificates can no longer be established. Charges and extent of the above mentioned certificates as well as the different tests confirmed therein are listed in our price list "Test and Inspection Charges for Standard Equipment".

For other tests and inspections than those listed above, please consult us.

PED (Pressure Equipment Directive)

The equipment complies with the requirements of the Pressure Equipment Directive 97/23/CE. Applicable with fluids of group 1 and 2. With CE marking (apart from equipment that is excluded from the scope of the PED according to section 3.3). For more information refer to our PED Declaration of Conformity.

ATEX (Atmosphère Explosible)

The equipment does not have its own potential source of ignition and is therefore excluded from the scope of the ATEX Directive 94/9/CE.

Applicable in Ex zones 0, 1, 2, 20, 21, 22 (1999/92/CE).

The equipment does not bear an Ex marking. For more information refer to our ATEX Declaration of Manufacturer.

GESTRA AG

P. O. Box 10 54 60, D-28054 Bremen

Münchener Str. 77, D-28215 Bremen

Tel. 0049 (0) 421 35 03-0, Fax 0049 (0) 421 35 03-393

E-Mail gestra.ag@flowserve.com, Web www.gestra.de



GESTRA

Distributor : Energy Technology Co., Ltd.

Tel.: +66 2 721 3860 - Fax.: +66 2 721 3869 - E-mail: sales@energytechnology.co.th - http:// www.energytechnology.co.th