

ZK 313-E/11 1" – 3"

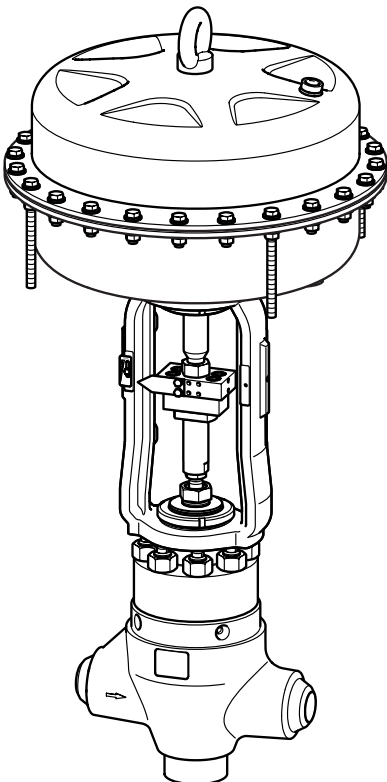

ZK 313-D/20 1" – 3"

Control Valve with ZK Radial Stage Nozzle® and Tandem Shut-Off ZK 313 ASME CLASS 2500 1" – 6"

Description

Control valve ZK 313 with ZK radial stage nozzle® designed for reducing high differential pressures in industrial installations and power plants and used as:

- Injection-cooling valve
- Continuous blowdown valve
- Warm-up valve
- Feedwater control valve
- Drain valve
- Leak-off valve
- Steam control valve

All internals are exchangeable. Leakage rating Class VI acc. to ANSI FCI 70-2-2003.

For equipment in sizes 1" – 3" two body types are available: straight-through and angle pattern. The body of equipment sizes 4" – 6" is hammer forged and of the angle or Z-type.

A sampling valve is available as optional extra on request.

Actuator and operation

The following actuators are available:

- 02: Handwheel (standard), retrofitting of an electric rotary actuator possible
- 11: Electric rotary actuator B1-F10 EN ISO 5210
- 12: Electric rotary actuator B1-F14 EN ISO 5210
- 13: Electric linear actuator
- 20: Pneumatically operated diaphragm actuator or piston actuator
- 31: Lever actuator equipped with quarter-turn actuator
- 40: Hydraulic cylinder

Pressure & temperature ratings

Admissible service pressure [barg] for body made from ASME materials

(calculated to ASME B16.34-Class 2500)

Temperature [°C]	Standard Class 1" – 6"			Limited Class 1" – 2 ½"		
	A105	F22	F91	A105	F22	F91
100	388	429	429	430	430	430
200	365	406	406	421	416	430
300	331	357	357	421	413	430
400	289	304	304	361	396	418
450	–	281	281	–	372	393
500	–	231	235	–	303	303
550	–	127	208	–	179	270
570	–	94	201	–	132	266
595	–	62	169	–	87	236
610	–	–	146	–	–	204
630	–	–	113	–	–	158

Admissible service pressure [psig] for body made from ASME materials

(calculated to ASME B16.34-Class 2500)

Temperature [°F]	Standard Class 1" – 6"			Limited Class 1" – 2 ½"		
	A105	F22	F91	A105	F22	F91
212	5632	6228	6228	6250	6250	6250
392	5294	5896	5896	6112	6047	6250
572	4812	5179	5179	6108	6000	6250
752	4196	4422	4422	5246	5744	6067
842	–	4087	4087	–	5395	5701
932	–	3361	3408	–	4408	4408
1022	–	1855	3017	–	2599	3926
1058	–	1369	2923	–	1917	3861
1103	–	906	2464	–	1271	3436
1130	–	–	2119	–	–	2967
1166	–	–	1645	–	–	2305

Admissible differential pressure Δ PMX:

	[barg]	[psi]
Single stage	40	580
Three stages	300	4,350
Three stages with additional nozzle	370	5,365

Materials

Component part	ASME
Body	A105
	A182 F22
	A182 F91
Upper part of body	A105
	A182 F91
Threaded bolt	A193 B16
Nuts	A194-7

Types of end connections

- Butt-weld ends
- Socket-weld ends
- Optional flange

Dimensions and weights

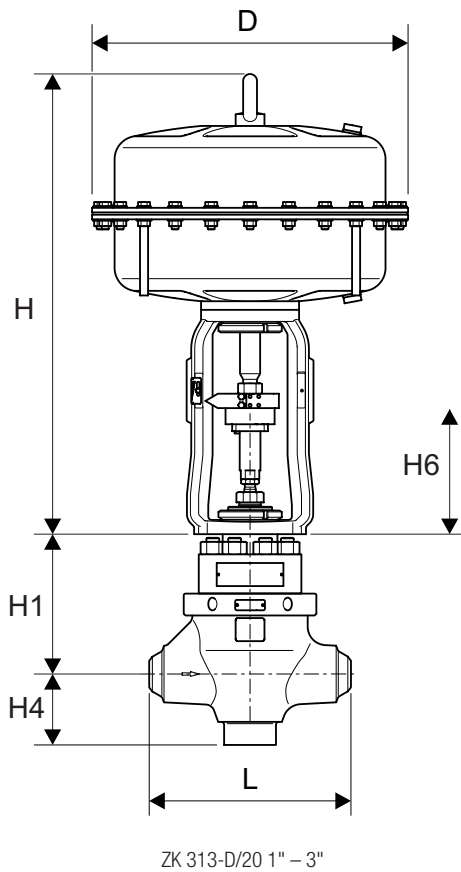
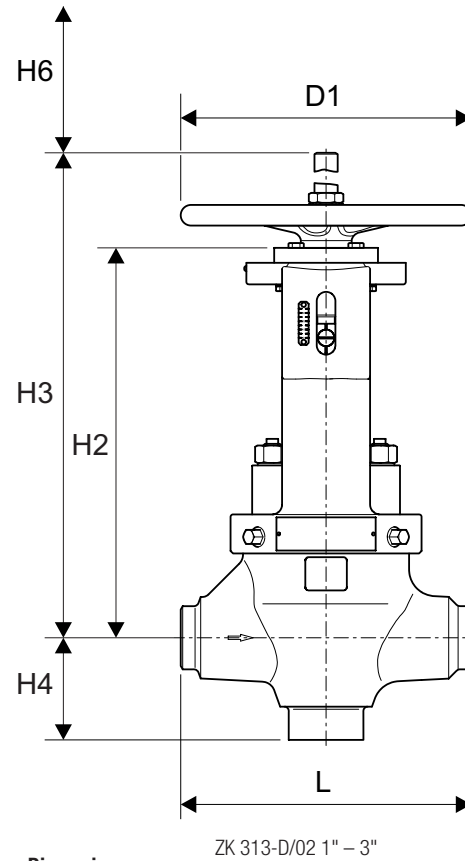
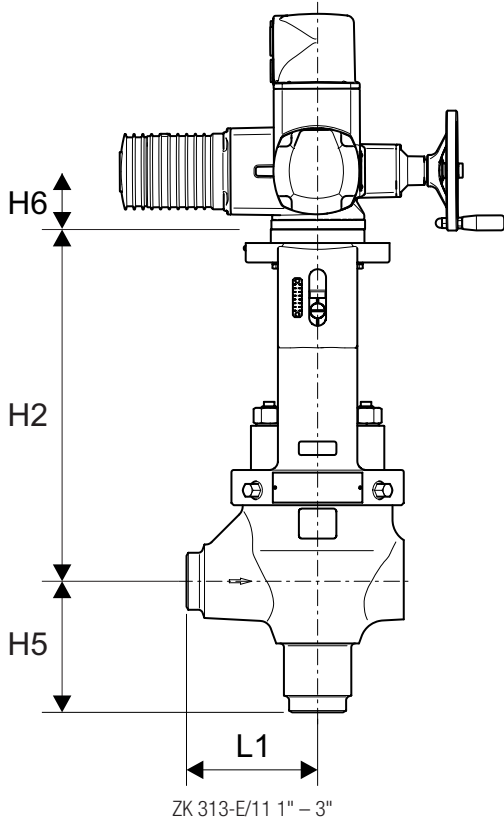

Dimensions

Valve size		1" – 3"	4" – 6"
H1	[mm]	243	243
	[in]	9.6	9.6
H2 max.	[mm]	484	484
	[in]	19.1	19.1
H3 (design/02)	[mm]	585	585
	[in]	23.0	23.0
H4	[mm]	123	–
	[in]	4.8	–
H5	[mm]	175	260
	[in]	6.9	10.2
H6 (space required for servicing)	[mm]	120	120
	[in]	4.7	4.7
H6 (space required for servicing, design/02)	[mm]	290	290
	[in]	11.4	11.4
L	[mm]	350	–
	[in]	13.8	–
L1	[mm]	175	260
	[in]	6.9	10.2
D1	[mm]	315	315
	[in]	12.4	12.4

Other dimensions available on request.

Weight, without actuator

Type	1" – 3"		4" – 6"	
	[kg]	[lb]	[kg]	[lb]
ZK313/02	100	220	–	–
ZK313/11	90	198	–	–
ZK313/12	90	198	–	–
ZK313/20	70	154	–	–
ZK313-E0, ZK313-Z0	–	–	on request	on request

Dimensions and weights of pneumatic diaphragm actuator

Dimensions	PB 700		PB 1502		PB 3002	
	[mm]	[in]	[mm]	[in]	[mm]	[in]
D	405	15.9	548	21.5	548	21.6
H	600	23.6	800	31.5	1,140	44.9
Weight	[kg]	[lb]	[kg]	[lb]	[kg]	[lb]
	40	88	124	273	240	528

Flow characteristics

K_vs values

	K _v s											Lift
	[m ³ /h]											
	equal percentage / linear									linear		
	Δp 300 bar			Δp 370 bar			Δp 40 bar					
1" – 3"	1	1.5	2.3	3.6	5.5	8.0	11.0	13.0	4.5	9.5	30.0	35.0
4" – 6"	–	–	2.3	3.6	5.5	11.0	14.5	17.0	4.5	9.5	46.0	35.0

C_v values

	C _v											Lift
	[US gal/min]											
	equal percentage / linear									linear		
	Δp 4350 psi			Δp 5365 psi			Δp 580 psi					
1" – 3"	1.2	1.7	2.7	4.2	6.4	9.2	12.7	15.0	5.2	11.0	34.7	1.4
4" – 6"	–	–	2.7	4.2	6.4	12.7	16.8	19.7	5.2	11.0	53.0	1.4

ZK Radial stage nozzle

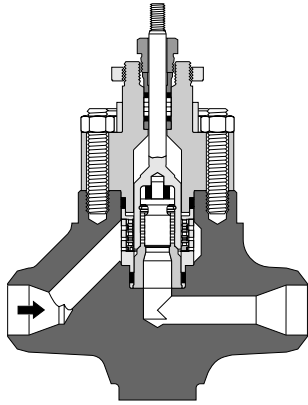

Standard nozzle
Δp_{max} 300 bar/4.350 psi

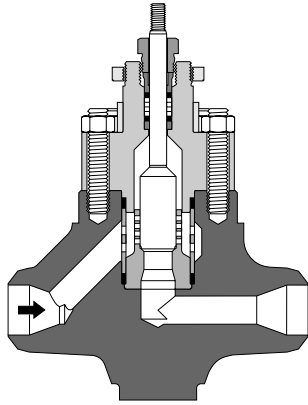

Special nozzle without tandem seat
Δp_{max} 40 bar/580 psi

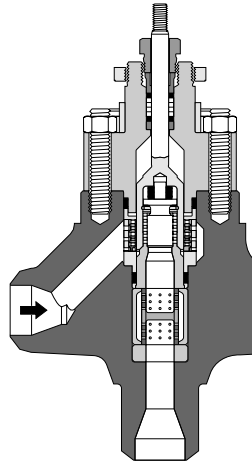

Special nozzle
Δp_{max} 370 bar/5.365 psi

Function

The ZK radial stage nozzle guarantees maximum wear resistance and ultra tight shut-off, combining the function of a control valve with a shut-off valve.

Each control valve is equipped with a ZK radial stage nozzle. This system consists of several sleeves nesting within one another, containing radial orifices drilled in them. By rotation of the sleeves, the orifices are shifted relative to one another, thus forming a large number of throttling points in parallel, with turbulence chambers (expansion chambers) in between.

The valve plug determines the flowrate through the ZK radial stage nozzle. Depending on its position, this valve plug opens up the individual orifices partially or completely, thus producing different flowrates.

As a result of this design, the pressure drop is reduced in steps and the medium flowing through is split up into many partial flows. This ensures high resistance to wear and reduces the noise level.

In addition the ZK 313 is provided with a dual shut-off system (tandem seat).

Function of the tandem seat

At the beginning of the opening process the valve plug first lifts off the main seat. The valve cone follows only after a certain lift of the valve plug. As a result, the flow velocities across the sealing surface are almost zero during the opening and closing process and, consequently, wire drawing is eliminated.

ZK Radial stage nozzle® with tandem seat

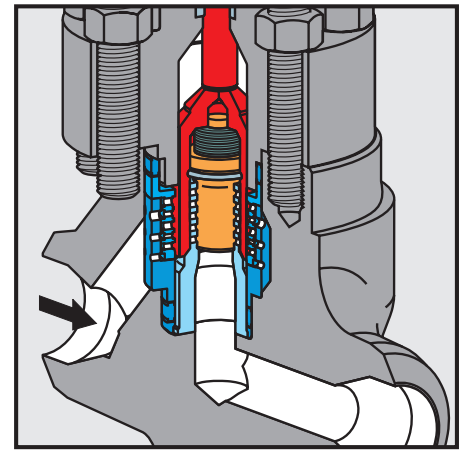

Valve plug in closed position

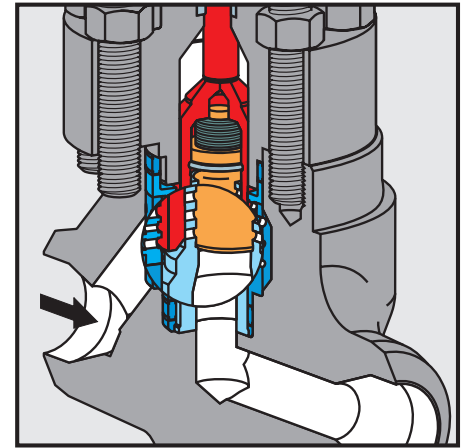

Valve no longer in closed position, but inner valve cone still closed

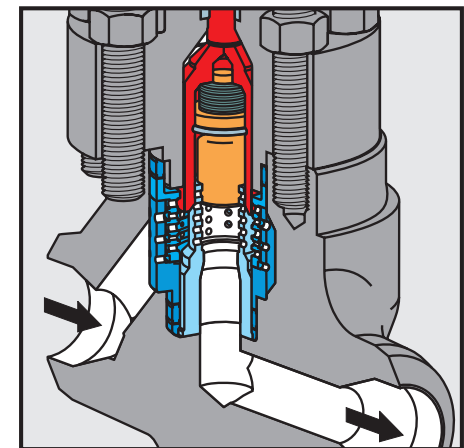

Valve plug in control position

Control Valve with ZK Radial Stage
Nozzle® and Tandem Shut-Off
ZK 313 ASME
CLASS 2500 1" – 6"

Capacity Charts

The charts show the max. flowrates of cold and hot (condensed) water at the extreme regulation position with linear characteristic curves and maximum K_v value.

Backpressure chart for hot water

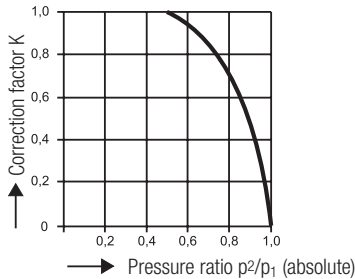

	K_v s value	C_v value
1	1.0	1.2
2	1.5	1.7
3	2.3	2.7
4	3.6	4.2
5	5.5	6.4
6	8.0	9.4
7	11.0	12.7
8	13.0	15.0
9	30.0	35.1

Specification Text

GESTRA Control Valve with Radial Stage Nozzle® ZK 313.
Design data: $p = \dots$ barg / psig, $t = \dots$ °C / °F or Class
Operation: Load conditions (1 to 3)

	1	2	3
P_1 [bara]/[psia]			
t_1 [°C]/[°F]			
P_2 [bara]/[psia]			
M [kg/h]/[lb/h]			

Please enter data.

Fluid:
Actuation: Electric (make)
ON / OFF or MODULATING CONTROL
Voltage/Hz
Actuation: Pneumatic (make)
Spring to open:
Spring to close:
Handwheel: yes/no
Positioner: yes/no

Inspection & Certification

Documentation regarding material tests and in-house examination with inspection certificate to EN 10204-3.1 or EN 10204-3.2 available at extra cost.

Please state the inspection and certification requirements when inquiring or ordering. After supply of the equipment certification cannot be established.

Charges and extent of the above mentioned certificates as well as the different tests confirmed therein are listed in our price list "Test and Inspection Charges for Standard Equipment".

For other test certificates please consult us.

Supply in accordance with our general terms of business.

Capacity chart, hot water $t_s - 5K$

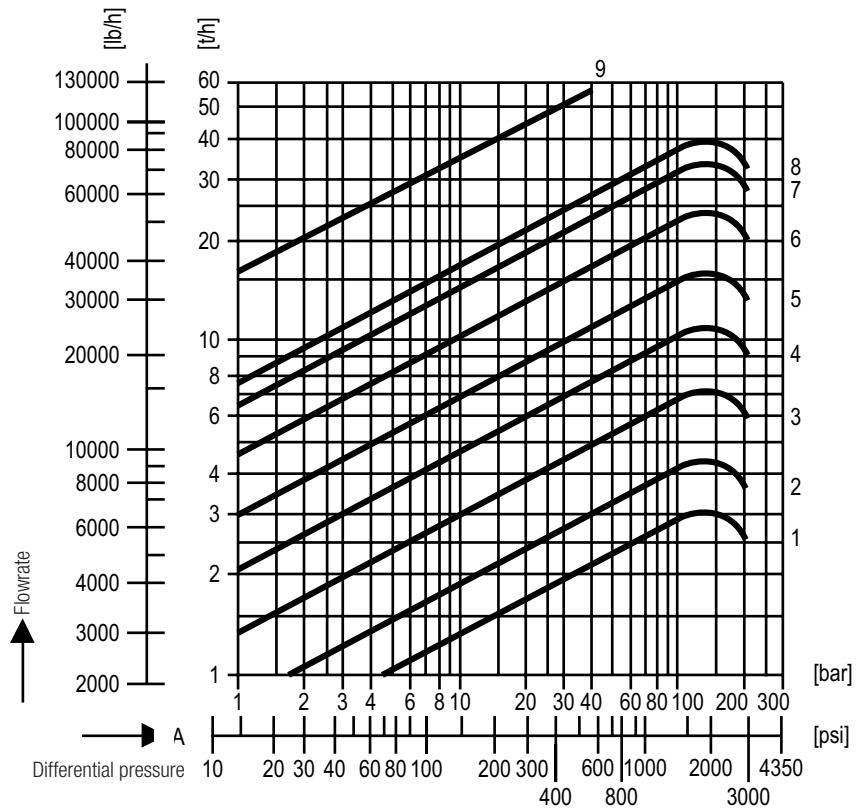

If $p_2/p_1 > 0.5$ multiply the capacity value by the correction factor K taken from the backpressure chart.

Capacity chart for cold water

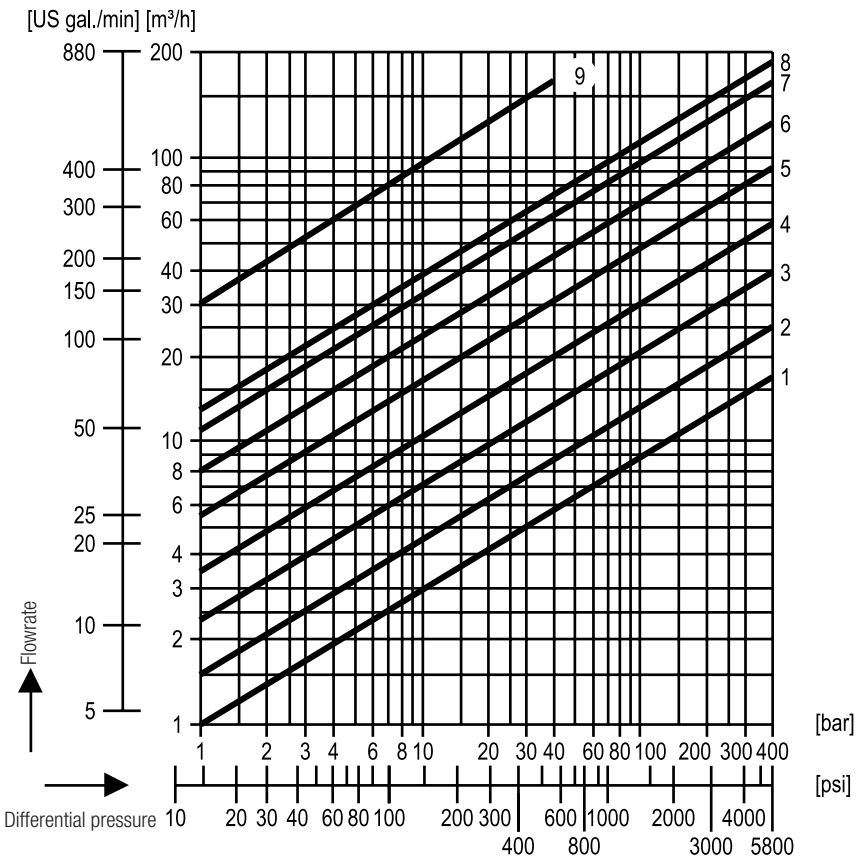

GESTRA AG

P. O. Box 10 54 60, D-28054 Bremen
Münchener Str. 77, D-28215 Bremen
Tel. 0049 (0) 421 / 35 03 - 0, Fax 0049 (0) 421 / 35 03-393
E-mail gestra.ag@flowserve.com, Web www.gestra.com



GESTRA

Distributor : Energy Technology Co., Ltd.

Tel.: +66 2 721 3860 - Fax.: +66 2 721 3869 - E-mail: sales@energytechnology.co.th - [http:// www.energytechnology.co.th](http://www.energytechnology.co.th)