

KS 90-1

## Description

The industrial controller KS 90-1 is used in conjunction with the conductivity transmitter LRGT 1... as continuous blowdown controller and conductivity limiter (to control the concentration of total dissolved solids =TDS), e. g. in steam boilers and (pressurised) hot-water plants. The industrial controller signals when the preset max. and min. limit is reached and controls the continuous blowdown valve BAE.

The industrial controller KS 90-1 is designed for use with the conductivity transmitter types LRGT 16-1, LRGT 16-2 and LRGT 17-1.

## Function

The industrial controller KS 90-1 processes the conductivity-dependent current signal of the conductivity transmitter LRGT 1... or an externally specified setpoint.

In the industrial controller KS 90-1 the input signal is standardized according to the conductivity measurement range and the switchpoints for MIN / MAX limits within this range are variably adjusted. During normal operation the actual value and the setpoint for continuous blowdown control are indicated on the seven-segment LED display.

When the MIN or MAX limit is reached, the MIN or MAX output contact is switched over and the LED for MIN or MAX is illuminated.

The industrial controller KS 90-1 works also as PI-type continuous blowdown controller. Once the adjusted setpoint is reached, the controller output contacts switch over according to the preset control parameters and the continuous blowdown valve is activated or deactivated. At the same time LED 2 (valve opens) or LED 1 (valves closes) lights up.

To avoid losing boiler water during stand-by operation you can energize the control input DI1 in order to de-activate the continuous blowdown control system and to close the continuous blowdown valve.

If faults occur in the electrical connection of the conductivity transmitter, a MIN alarm is triggered and the continuous blowdown valve closes.

## Industrial Controller KS 90-1

### Technical data

#### Supply voltage

90 – 250 VAC, 48 – 62 Hz

#### Power consumption

8.0 VA

#### Inputs

1 actual value input INP1, 4-20 mA, for conductivity transmitter LRGT 1... , screened, with 2 poles.

1 supplementary input INP2, 4-20 mA, for external set-point selection

2 control inputs DI1, DI2, configured as switch for connecting volt-free contacts, switched voltage: 5 V, current 100 µA.

#### Outputs

Relay outputs OUT1...OUT4:

Volt-free change-over contact:

Max. contact rating: 500 VA, 250V, 2A at 48...62 Hz, resistive load

Min. contact rating: 6 V, 1 mA DC.

Switching cycle, electric: For I = 1 A/2 A: > 800.000 / 500.000 (at AC 250 V (resistive load))

Provide inductive loads with RC combinations according to manufacturer's specification to ensure interference suppression.

#### Indicators and adjustor

1 display with bar chart and plain text

4 amber LEDs with relay outputs OUT1...OUT4,

4 pushbuttons for parameter setting and selection manual/automatic.

#### Enclosure

Plug-in module to DIN 43700 for installation in control panel and control cabinet

Cut-out dimensions 45<sup>+0.6</sup> x 92<sup>+0.8</sup>.

Makrolon 9415 flame-retardant,

Flammability class: UL 94 V0, self-extinguishing.

#### Electrical connection

Screw terminals for conductor cross-section from 0.5 to 2.5 mm<sup>2</sup>.

#### Safety & protection

Overvoltage category II

Contamination class 2

Operating voltage range 300 V

Protection II

#### Protection

Front: IP 65 to EN 60529

Enclosure: IP 20

Connections: IP 00

#### Weight

approx. 0.27 kg

#### Ambient temperature

during operation 0 ... 60 °C

#### Transport temperature

-40 ... +70 °C (<100 hours), defrosting time of the de-energized equipment before it can be put into operation: 24 hours.

#### Storage temperature

-40 ... +70 °C, defrosting time of the de-energized equipment before it can be put into operation: 24 hours.

#### Relative humidity

75 % yearly average, no condensation

#### Approvals:

TÜV certificate

Type approval: TÜV . WÜL . XX-003 (see name plate)

### Important Notes

If the equipment is used as conductivity limiter connect the safety circuit for the heating to the terminals 10/12 (OUT3). Provide an external slow-blow fuse 1.2 A for the output contact.

The equipment does not interlock automatically in the event of an alarm (MAX limit exceeded). If an interlock function is required for the installation it must be provided in the follow-up circuitry (safety circuit). The circuitry must meet the requirements of the EN 50156.

To connect the conductivity transmitter use screened multi-core control cable with a min. conductor size 0.5 mm<sup>2</sup>, e. g. LiYCY 2 x 0.5 mm<sup>2</sup>, max. length: 250 m.

Wire terminal strip in accordance with the wiring diagram. Connect the screen **only once** to the conductivity transmitter.

Make sure that connecting cables leading to the equipment are segregated and run separately from power cables.

To avoid losing boiler water during stand-by operation you can energize the control input DI1 in order to de-activate the continuous blowdown control system and to close the continuous blowdown valve.

The control input is energized by a volt-free make contact connected to the terminals 1 and 2 of terminal strip A1.

The external setpoint selection can be activated by energizing the control input DI2.

The control input is energized by a volt-free make contact connected to the terminals 2 and 3 of terminal strip A1.

Connect the external setpoint 0/4 -20 mA to terminals 6 and 7+ of terminal strip A1.

When switching off inductive loads, voltage spikes are produced that may impair the operation of control and measuring systems. Connected inductive loads must be provided with suppressors such as RC combinations as specified by the manufacturer.

Industrial Controller  
**KS 90-1**

**Order and Enquiry Specification**

Stock code # 2661644  
 Ref. number 1503210  
 Controller type KS 90-1  
 Protection Front IP 65, enclosure IP 20.  
 Indicators & adjustors 1 display showing actual value and setpoint  
 4 LEDs, amber, for relay outputs OUT1 .. OUT4.  
 Input 2 standard signals 4-20 mA, 2 control inputs.  
 Output 4 relays as volt-free change-over contacts.  
 Configuration as three-position stepping controller with 1 MIN and 1 Max alarm.  
 Incl. manual/automatic switch-selection  
 Mains voltage 90-250 VAC, 48-62 Hz

**In conjunction with LRGT ...**  
**Power supply unit type "Power 0,5"**  
 Stock code # 3373041  
 with casing for supporting rail mounting, 22.5 x 80 x 91 mm.  
 Input 230 V, 50 Hz  
 Output 24 V DC / 500 mA  
 Protection IP 20

- Ancillaries**
- Conductivity transmitter LRGT 1.-1, LRGT 16-2
  - Power supply unit SITOP power 0,5
  - Continuous blowdown valves BAE 46, BAE 47, BAE 210, BAE 211

**VdTÜV Bulletin "Water Monitoring 100"**  
 The industrial controller KS 90-1 in conjunction with the conductivity transmitter LRGT 1.-... is type approved according to VdTÜV Bulletin "Water Monitoring 100". The VdTÜV Bulletin "Water Monitoring 100" states the requirements made on water monitoring equipment.

**LV (Low Voltage) Directive and EMC (electromagnetic compatibility)**  
 The equipment meets the requirements of the Low Voltage Directive 2006/95/EC and the EMC Directive 2004/108/EC.

**ATEX (Atmosphère Explosible)**  
 According to the European Directive 94/9/EC the equipment must not be used in potentially explosive areas.

Supply in accordance with our general terms of business.

**Dimensions**

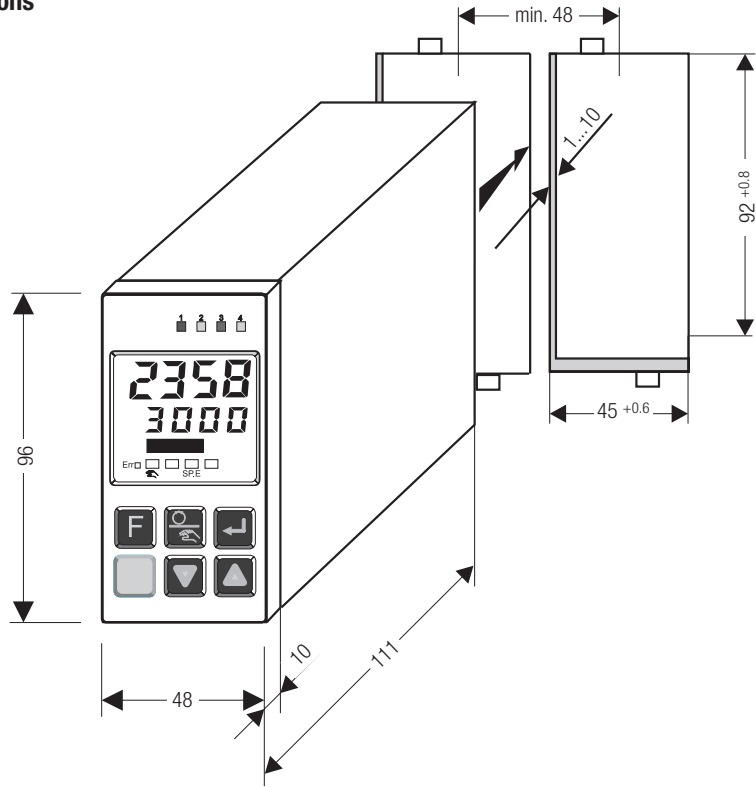

**Wiring diagram**

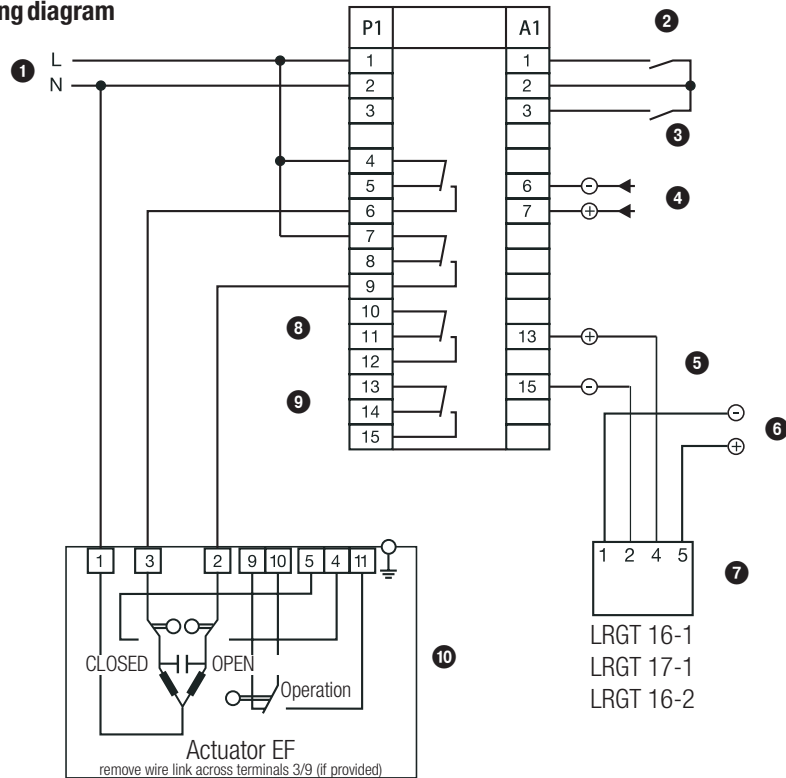

**Key**

- 1 Connection of supply voltage 90 .. 260 V AC
- 2 Control input DI1, stand by, control OFF
- 3 Control input DI2, external setpoint selection
- 4 INP2, connection for external setpoint
- 5 INP1, connection for conductivity transmitter
- 6 Connection of supply voltage 24 V DC for conductivity transmitter
- 7 Conductivity transmitter
- 8 MIN output contact OUT3
- 9 MAX output contact OUT4
- 10 Actuator EF

**GESTRA AG**

P. O. Box 10 54 60, D-28054 Bremen  
 Münchener Str. 77, D-28215 Bremen  
 Tel. 0049 (0) 421 35 03-0, Fax 0049 (0) 421 35 03-393  
 E-mail gestra.ag@flowserve.com, Web www.gestra.de



GESTRA

**Distributor : Energy Technology Co., Ltd.**

Tel.: +66 2 721 3860 - Fax.: +66 2 721 3869 - E-mail: sales@energytechnology.co.th - http:// www.energytechnology.co.th