

GESTRA Steam Systems

Low-Level Limiter / Limiting System Type NRS 1-40

Product Range B

NRS 1-40

Description

Low-level limiter with one level electrode

The switching controller type NRS 1-40 is a self-monitoring low-water level limiter with periodic self-checking and monitoring feature of the output relay contacts, to be used in conjunction with **one** level electrode type NRG 16-40, 17-40 or 19-40. The controller has the following function:

- Low-water level alarm with **one** switchpoint

The equipment detects the min. water level (low-level limiter) and complies with the German Regulations for use in steam and hot-water plants operating without constant supervision according to TRD 401 and TRD 602.

Low-level limiting system with two level electrodes

When used with **two** level electrodes type NRG 16-40, 17-40 or 19-40, the controller NRS 1-40 constitutes a high-integrity low-water level limiter **system** with periodic self-checking. The controller features the following function:

- Low-water level alarm with **one** switchpoint, dual-channel redundancy

Application in steam and hot-water plants operating without constant supervision according to TRD 604, sheet 1 and 2 (24/72 hrs.) and EN 12952, EN 12953.

This item of electrical equipment complies with the Technical Regulations on Protection Circuits to DIN VDE 0116 (prEN 50156).

The level data are transferred from the electrode NRG 1...-40 to the controller via CAN bus using the CANopen protocol.

Function

At regular intervals the level electrode NRG 1...-40 sends a data telegram to the controller NRS 1-40. The data transfer is effected by means of a CAN bus according to DIN ISO 11898. The transferred measuring data are constantly evaluated by the controller. A periodic self-checking routine tests every 3 seconds the integrity of the system and its safety functions, with a malfunction in the controller resulting in immediate boiler shut-down. When the CAN bus line and, consequently, the data trans-

mitting cycle are interrupted, the controller sends a visual signal to indicate a faulty condition and the relays are instantaneously de-energized (fail-safe position).

The controller also facilitates user-friendly performance tests and detection/evaluation of malfunctions.

To guarantee the correct and safe functioning of the low-level limiter a min. electrical conductivity of 0.5 µS/cm at 25 °C is required.

The relay de-energizing delay is normally set to 3 seconds at the factory but delays of 15 to 25 seconds are available on request.

Apart from the burner protection circuit there is also a separate Photo-MOS make contact output for remote indication.

Design

NRS 1-40 b

Enclosure of insulating material with externally accessible terminals.

Clipping onto a 35 mm standardized supporting rail (DIN EN 50022).

External dimensions: 73 x 100 x 118 mm

CAN-Bus

All controllers and associated level electrodes are interconnected by means of a CAN bus using the CANopen protocol. Every item of equipment features an electronic address (node ID). The four-core bus cable serves as power supply and data highway for high-speed data exchange.

The CAN address (node ID) for the NRS 1-40 can be set between **1** and **123**.

The low-level limiter, consisting of **one** level electrode and **one** controller, is configured at our works and ready for service. The low-level limiter can be used straight away without having to set the node ID.

For a low-level limiter **system**, consisting of **two** level electrodes and **one** controller, the **second** level electrode has to be configured. The low-level limiter system can be used after setting the respective node IDs. The baud rate set at our factory is 250 kb/s.

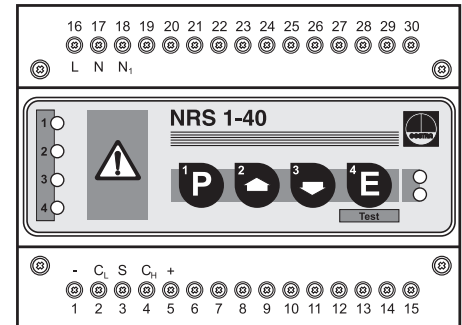

CANopen

The CANopen bus for the controller type NRS 1-40 uses the CANopen protocol. A separate Electronic Data Sheet is available detailing the configuration procedure.

Technical Data

Type approval no.

TÜV · SWB/SHWS 02-403
EG BAF-MUC 0202 103881 002

Input / Output

Interface for CAN bus to DIN ISO 11898 CANopen

Output – voltage supply for electrode(s)

18 – 36 V, short-circuit protected

Output – for protection circuit

Two volt-free relay contacts, locally connected in series. Max. contact rating for switching voltages 24 V AC/DC, 115 V AC and 230 V AC: 4 A resistive/inductive. Contact material: AgNi 0,15

Interference suppression

Provide contactor with external RC combination (100 Ω/47 nF)

Signal output

Photo-MOS output, instantaneous low-level alarm, timed malfunction signal, max. contact rating for switching voltages 24 V AC, 115 V AC and 230 V AC/DC: 100 mA resistive

P.T.O

Important Note

Note that screened multi-core twisted-pair control cable is required, e. g. UNITRONIC® BUS CAN 2 x 2 x ...² or RE-2YCYV-fl 2 x 2 x ...².

The baud rate (data transfer rate) dictates the cable length between the bus nodes and the total power consumption of the measuring sensors dictates the conductor size.

S 8	S 9	S 10	Baud rate	Cable length	Number of pairs and conductor size [mm ²]
OFF	ON	OFF	250 kBit/s	125 m	2 x 2 x 0.34
Factory setting					
ON	ON	OFF	125 kBit/s	250 m	2 x 2 x 0.5
OFF	OFF	ON	100 kBit/s	335 m	2 x 2 x 0.75
ON	OFF	ON	50 kBit/s	500 m	on request, dependent on bus configuration
OFF	ON	ON	20 kBit/s	1000 m	
ON	ON	ON	10 kBit/s	1000 m	

The baud rate is set via a code switch. Reduce baud rate if cable is longer than specified in the table. Make sure that all bus nodes have the same settings.

To protect the switching contacts fuse circuit with 2.5 A (anti-surge fuse) or according to TRD regulations (1.0 A for 72 hrs operation).

Low-Level Limiter / Limiting System Type NRS 1-40

Technical Data – continued –

Relay de-energizing delay

Output “Low-level alarm”, set to 3 sec. (15 or 25 sec. available for marine applications) internally linked for relay contact test

Indicators and adjustors

- 4 pushbuttons “Parameterisation/TEST”
- 1 red LED “Low-level alarm electrode 1”
- 1 red LED “Low-level alarm electrode 2”
- 2 red LEDs for multiple functions
- 1 red LED “Bus status”
- 1 green LED “Power”
- 1 ten-pole code switch: 7 poles for setting node ID, 3 poles for setting baud rate
- 1 two-pole code switch for limiter/limiter system

Internal self-checking routine

Every 3 seconds

Periodic testing of output relay contacts

Every 6 hours

Supply voltage

- 230 V +/- 10 %, 50/60 Hz
- 115 V +/- 10 %, 50/60 Hz (optional)

Power consumption

10 VA

Sensitivity

≥ 0.5 μS/cm at 25 °C

Protection

- Enclosure: IP 40 to DIN EN 60529
- Terminal strip: IP 20 to DIN EN 60529

Admissible ambient temperature

0 °C to 55 °C

Enclosure material

- Front panel: polycarbonate, grey
- Enclosure: polycarbonate, black

Weight

Approx. 0.8 kg

Order and Enquiry Specification

GESTRA Level Switch type NRS 1-40

Controller

Mains voltage V

Level electrode with external chamber (yes/no)

Ancillary Units

- Conductivity level electrode type NRG 16-40
- Conductivity level electrode type NRG 17-40
- Conductivity level electrode type NRG 19-40
- Conductivity level electrode type NRG 111-40
- Logic control unit type SRL 6 for monitoring purging cycle if external chamber is used

Supply in accordance with our general terms of business.

Dimensions

MAX 55 °C

MAX 95 %

IP 20

CE

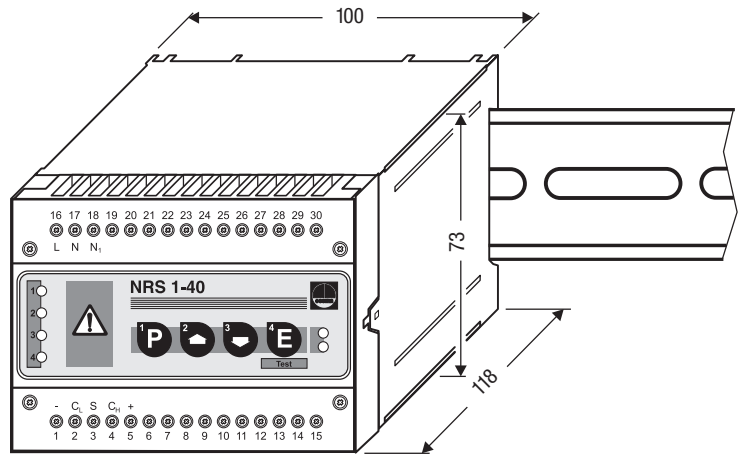

Wiring Diagram

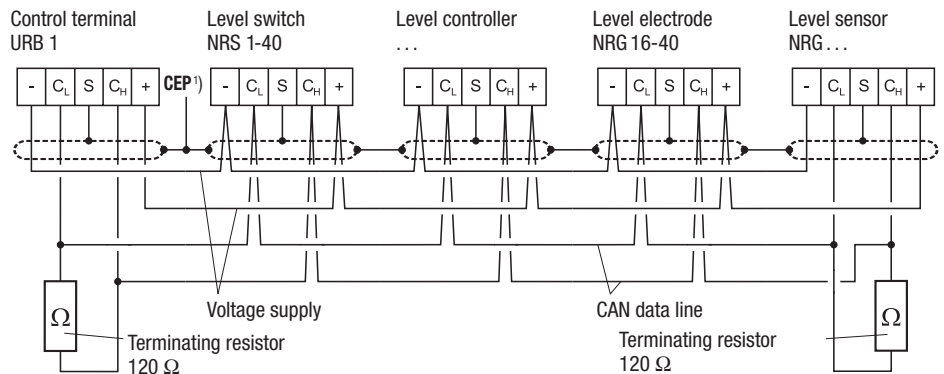
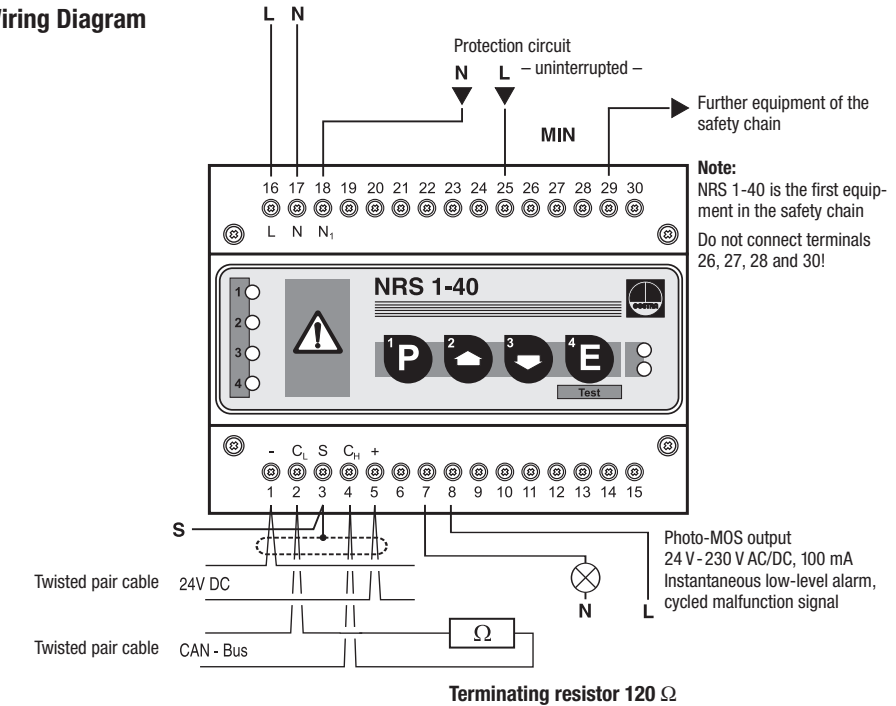

1) CEP = central earthing point

GESTRA AG

P. O. Box 10 54 60, D-28054 Bremen
Münchener Str. 77, D-28215 Bremen
Telephone +49 (0) 421 35 03 - 0, Fax +49 (0) 421 35 03-333
E-Mail gestra.ag@flowsolve.com, Internet www.gestra.de



Distributor : Energy Technology Co., Ltd.

Tel.: +66 2 721 3860 - Fax.: +66 2 721 3869 - E-mail: sales@energytechnology.co.th - http:// www.energytechnology.co.th