

THE LEADER IN FLUID HANDLING SOLUTIONS





THE LEADER IN FLUID HANDLING SOLUTIONS

PUMPS AND PUMPING SYSTEMS
STEAM AND CONDENSATE SYSTEMS
BOILER CONTROL EQUIPMENT
EXPANSION JOINTS
ENGINEERING AND SERVICES

At Energy Technology,
Our focus is on serving customers.

By bringing together strong brands with the best people, the group has today become one of the great service providers of pumps and pumping systems, total solutions of steam and condensate systems, boiler control equipment, and is a key player in high quality of services and engineering design.

Every day we aim to earn your confidence. We work hard to become and remain your preferred partner.

HOW CAN WE SUPPORT YOUR BUSINESS?

At Energy Technology, we believe the right solution for you goes beyond simply supplying a product.

We work together with you to better understand your needs. We deliver the right solutions for all your fluid handling challenges, no matter how simple or how complex.

Our diverse pool of people, knowledge and specializations feeds a culture of innovation that continuously improves our offering to better meet your evolving challenges.

Energy Technology is committed to delivering reliability, efficiency and reassurance. We do this by understanding your needs.



CONSULTING, SALES AND SERVICES FOR FLUID HANDLING SYSTEMS, THE EXPERIENCE AND KNOW-HOW TO PROVIDE RELIABLE SOLUTIONS

For over 30 years, our experts have established an enviable reputation in the design and development of solutions for fluid handling.

In parallel, we have supported our customers by selling a wide range of products related to the transport of fluids, handling steam - condensate and provide steam boiler equipment.

In fact, we supply a comprehensive catalogue of over 10,000 items. Our involvement extends to providing specialised after-sales service, and delivering training and assistance, customised to the needs of each client.

The sectors we serve are extremely diverse, ranging from the chemical, petrochemical, refinery, power plant, sugar mill, foods, rubber industries, boiler makers, water treatment and water transport.

CENTRIFUGAL PUMPS

CHEMICAL PROCESS PUMPS

MAGNETIC DRIVE PUMPS

VACUUM PUMPS

ROTARY LOBE PUMPS

EXPANSION JOINTS

LEVEL SWITCHES

STEAM TRAPS

NON-RETURN VALVES

CONTROL VALVES

BOILER EQUIPMENT

CONDENSATE MORNITORING

VESSELS FOR HEAT RECOVERY



EXPERTISE IN SERVICE SOLUTIONS

Our services are tailored and integrated to suit your resources, plant requirements, and budget. Qualified and experienced engineers will work with you to implement the improvements to your system and then help you to maintain the resulting performance gains which usually give very rapid returns on your investment.



1. Pump Inspection, Overhaul, Installation and Running Test
155 m³/h – 150 bar – 850 kW

2. Pump Inspection, Overhaul, Installation and Running Test
Pump size : 800x600, 1670 HP

3. Laser Alignment for
Critical High-Pressure Pump

4. Vibration Analysis for
Chilled Water Pumps

5. Supply, Installation and Commissioning
of High Pressure Control Valve
8 inches in 72 bar at 532 °C

6. Supply, Installation and Commissioning
of Deaerating Plant 50 ton/hr

7. Supply, Installation and Commissioning
of Heat Recovery Package 8 ton/h



ROTAMAC



PUMP DESIGN

The success of an installation starts with selecting the right pump. The type, size, seal and accessories must satisfy the Requirements presented by the pumped medium.

MATERIAL ADVICE

Whether you require pump materials, seal materials or changes in process affecting the pumps – our material specialists will offer you an individual recommendation, with full commitment.

OPERATING CONCEPT

Whether you want to monitor centrifugal pumps or operate complex vacuum installations, we will work with you to devise the right operating concept which meets your needs – from manual to fully automatic.

DOCUMENTATION

You need documentation? Whether standard or project, according to your requirements we create your individual project documentation.

INDIVIDUAL APPROVAL

All centrifugal and vacuum pumps as well as package pumping systems are tested at factory before they are delivered: Together with our customers, specific details and processes are tested and discussed.

ON-SITE SUPPORT

Whether it is for initial start-up or for training your personnel. Our engineers are also available to assist you on site.



EXPERTISE IN INDUSTRIAL PUMP SYSTEMS

ROTAMAC is an experienced partner and supplier of industrial pumps, solid handling pumps and chemical process pumps to customers in the building, waterworks, chemical, petrochemical, power, rubber, sugar, food and beverage, and pulp and paper industries.

We can supply a range of centrifugal pumps designed and manufactured in accordance with EN 733 / DIN 24255, ISO 5199 / ISO 2858 or API 610 / ISO 13709.

The basis for our comprehensive pump range are the two material groups Metal and Plastics. This wide variety of materials and more than 30 different pump types offer the right solution for your project.

In close communication with you our experienced project teams develop individual concepts for your sophisticated application. And if you need a standardized application just profit from our extensive pump range.



ROTAMAC



Not just a pump supplier, but ROTAMAC has experience as a contractor for pumping stations.

The pump is at heart of any water / wastewater / chemical transfer scheme.

ROTAMAC is not only a pump supplier but we have a long history of design of pumping stations. We are committed to providing a turnkey service to our customers where we can design, engineering, procure, construct and commission all the equipment within the pumping station. We have expertise in water distribution, wastewater, cooling, slurry, solids handling and process pumps.



1. Supply, Installation and Commissioning of Split Casing Double Suction Pumps
2500 m³/h - 40 m - 355 kW

2. Supply, Installation and Commissioning of Vertical Shaft Mixed Flow Pumps
1800 m³/h - 15 m - 110 kW

3. Supply, Installation and Commissioning of High Pressure Multi-Stage Pumps
40 m³/h - 410 m - 110 kW

4. Supply, Final Alignment and Commissioning of ASME B73.1 Pumps

5. Supply, Final Alignment and Commissioning of Self Priming Pumps

6. Supply and Final Alignment of Split Casing Double Suction and DIN24255 Pumps

7. Supply and Commissioning of Liquid Ring Vacuum Pumps
3100 m³/h - 846 mbar - 90 kW



ROTAMAC



End Suction

Single-stage horizontal shaft pumps with main dimensions and characteristics conforming to EN733 (DIN 24255) standards. Available in close coupled designed.



Vertical Inline

The pumps are used in commercial buildings for air conditioning and heating applications with inline design for space saving and reduce the amount of piping.



Sheet Metal

Compact designed sheet metal pumps, primarily used as a built-in pump in OEM solutions and domestic boosters. Available in single stage, vertical or horizontal multi-stage.



Pressure Booster

Fully integrated, all-in-one packaged systems are designed to handle even the most difficult applications with ease and accuracy.

WASTEWATER



Submersible

Powerful submersible pumps for handling sewage water, suitable for handling solids in both municipal & industrial wastewater applications.



Self Priming

The large volute design allows solid handling, automatic re-priming without the need for suction or discharge check valves.



Sewage [Non Clog]

These series pumps are used for pumping rain, raw and mixed water with suspended solids, muddy water, sewage water, other solid – liquid mixtures.



Semi-Open Impeller

End suction heavy-duty pumps, semi-open extra thick impeller with front wear plate, built to stand up to the toughest services with maximum reliability.



Vertical Sump

These pumps are intended for use in the industrial applications to pump clean or lightly contaminated liquids, fibrous slurries and liquids containing solids from the deep sumps.



WATER DISTRIBUTION



Vertical Turbine

Available in variety of construction and material to suit applications, Open or enclosed line shaft, above ground or below ground discharge flanges multiple drives with motor or engine.



Vertical Mixed Flow

The pumps are large capacity, vertical, mixed-flow pump suitable for a wide range of application, such as seawater intake, cooling water, drainage, etc.



Mixed Flow

The pumps are large capacity, mixed-flow, designed specifically for reliability, low cost and long life in demanding raw water services.



Double Suction

Medium to large capacity axially split volute double suction pumps are custom-design to suite with the requirement. Available in both horizontal and vertically mounted configurations.

FIRE FIGHTING



Pump Package

State of the art engineered systems arrive ready to install. Pump, driver and controller are mounted on a common base. All pump meet the requirements of NFPA20.



Single Stage Split Case

These pumps have a horizontal pump shaft with the impeller placed in the middle of the shaft, available in both horizontal and vertically mounted configurations, complying with NFPA 20.



Two Stage Split Case

Integral cross-over passages provide high efficiency and stable head-capacity characteristics. Axial & radial thrust loads are fully balanced for this class of pumps, TDH up to 500 m (711 psi), complying with NFPA 20.



Vertical Turbine

The pump with a discharge head, top mounted or right angle gear drive that are either diesel or electrical driven. Which is suitable for fire fighting pumps complying with NFPA 20.



Fire Protection Equipment

- Expansion Joints
- Wet Alarm Valves
- Pressure Relief Valves
- Pressure Reducing Valves
- NSR Gate Valves
- OS&Y Gate Valves
- Butterfly Valves
- Check Valves
- Sprinklers



ROTAMAC



ANSI / ASME B73.1

This versatile pump line is offered in a wide range of constructive materials and variety of shaft sealing systems that allow the pump to work with many different kinds of fluids, from corrosive and non-corrosive liquids



ISO 5199 / ISO 2858

These are standardized pumps, metallic centrifugal, single stage. Handling of aggressive liquids in the chemical and petrochemical industries as well as in refinery, handling of brine and fire-fighting systems.

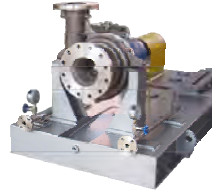

API 610

It has the broadest performance range in the industry and is used in heavy-duty refinery, gas, petrochemical and offshore oil production services. Available in several designed as OH2, OH3, BB1, BB2, BB4, VS4.



High Pressure Multi-Stage

These are horizontal multistage ring section pump specifically designed for high pressure services such as power stations, incineration plants and HRSG.

PULP AND PAPER PROCESS



Low Consistency

There are used as process pumps in many different areas of pulp and paper mills. The wide range of impeller selection enable to pump suspensions at consistencies of up to 8%, offer high efficiencies.



Medium Consistency

There are used for demanding medium consistency fibrous slurry applications up to 16%, ensure process reliability, low operating costs, high efficiency, easy maintenance and service.



Degassing Self-Priming

The pump is designed to meet those special pumping situations, to enable the pump to be started with an empty inlet pipe and to allow it to pump liquids with high gas content.



Headbox Feed

Low pulsation impellers are designed to meet the stringent performance requirements of paper machine head box applications. High-capacity, reliability, high efficiency, and low operating costs.



Closed



Semi-Open



Open



Low Pulse



Non Clog



Special Open



Low Flow



Slurry



Vortex



Vortex [cup type]

Variety of Impellers

Reliable and efficient impellers to reduces life cycle costs, energy consumption, operation time and downtime. Improved efficiency and NPSHr by verified hydraulic design of impellers.

INDUSTRIAL PROCESS



Magnetic Drive

Stainless steel magnetic drive pumps are ideal to meet the stringent requirements of chemical processing and a multitude of other industries.



Thermic Fluid

These hot water or thermal oil pumps are particularly suitable for use in heat transfer systems or for hot water circulation. Designed for users in the chemical, rubber, plastic, paper and laundries industry.



Slurry

The heavy duty slurry pump range is designed to perform continuous pumping of highly abrasive/dense slurries in minerals processing plants as well as other industrial applications.



Low Flow

Designed specifically for trouble free operation at low flows. The pump casing and open radial vane impeller are designed to eliminate hydraulic and mechanical problems at throttled low flows.

VACUUM AND COMPRESSOR



Small Capacity

These liquid ring pumps are available in a variety of materials including cast iron, stainless steel. Particularly space-saving, reliable and robust in their monoblock design.



Medium & Large Capacity

Medium to large capacity single stage pumps are ideal for demanding applications in extremely tough conditions. These heavy duty pumps are able to service a wide range of applications.



Two Stage

Two stage pumps are ideal for a variety of industrial applications and may be combined with ejectors or boosters to form hybrid packages, allowing higher pressure levels.



Dry Screw

The dry and contact free operation requires no lubrication in the pumping chamber. This translates into major advantages: no process contamination and no pollution caused by the pump operation.



Engineered Systems

Simplify your installation with a packaged system. Engineered Systems are delivered with all of the necessary components assembled and piped. You receive a complete system that is ready to install.

ROTAMAC



Diaphragm Metering

It features a high level of repetitive accuracy and is capable of pumping a wide range of chemicals including corrosives or viscous liquids. Pump head made of PVC, PTFE, 304/316 stainless steel, diaphragm in PTFE.



Plunger Metering

High performance and accuracy dosing features. The plunger makes harmonic push and pull motion by the crankshaft. It is widely used in industries such as chemical, petrochemical, boiler, etc.



Gear

A gear pump uses the meshing of gears to pump fluid by displacement. They are one of the most common types of pumps for hydraulic fluid power applications.

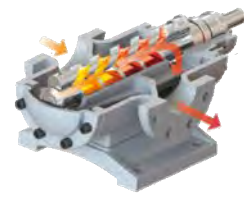

Screw

A screw pump that use one or several screws to move fluids or solids along the screw(s) axis. The range consists of 3 series, available in single, twin or three screw.

NON METALLIC



ISO 5199 / ISO 2858

Handling of aggressive liquids in the chemical and petrochemical industries. Additionally the armoured pump casing absorbs the external forces acting on the pump.

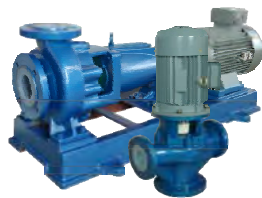

Plastic Lined

Plastic-lined pumps are an alternative to pumps made of expensive special materials. The wetted parts are compatible with the corrosive liquid and designed for users in the chemical industry.



Self Priming

The main feature of this type of pump is the suction of liquids from a negative suction. Pump casing made of plastic lined and available in close coupled designed.



Magnetic Drive

The pump is engineered to provide low total cost of ownership and exceptional leakage protection in extremely corrosive and environmentally critical applications.



Vertical Sump

All parts in contact with the liquid are made of strong solid plastic, the heavily constructed shaft has been given a nonporous plastic coating. Handling of aggressive liquids and contaminated liquids.

POSITIVE DISPLACEMENT



Rotary Lobe

It is similar to a gear pump except the lobes are designed to almost meet, rather than touch and turn each other. This makes that this type of pump is often used in industries including chemical, food, beverage and biotechnology.



Progressive Cavity

Also known as an eccentric screw pump or cavity pump. It transfers fluid by means of the progress, through the pump, of a sequence of small, fixed shape, discrete cavities, as its rotor is turned.

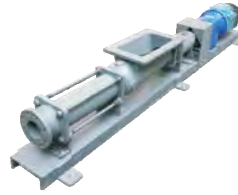

Hopper

There are fitted with feeder hopper and conveyor screw. The open-throat design allows the fluid to flow in without restriction while the screw feeds the materials into the rotor/stator.



Rota [Masecuite]

Designed to handle high viscosity abrasive sugar products with higher brix that contains sugar crystals such as masecuite, magma and dry seed for sugar industries.

SPARE PARTS

Minimize future breakdowns with 100% interchange spare parts

Our manufactures several different designs of horizontal and vertical pumps, vacuum pump and compressor, some of them have the added benefit of interchanging with the most popular pump in the world such as :

- NASH vacuum and compressor : 2BE, CL and AT series
- Goulds ASME B73.1 : 3196 series
- SIHI vacuum and compressor : LPH series
- Flowserve ASME B73.1 : Durco Mark 3 series
- Sulzer ISO 5199 / ISO 2858 : AHLSTAR range , comprised of the A, N and W ranges
- Warman slurry : AH, AHR, XU, SP and SPR series

Totally interchangeable, quality engineered, special parts requests are always welcome.

Cross-referenced parts from the Original Equipment Manufacturer "OEM" are listed for information purposes only. Trademarks identifying these parts for cross-reference are those of each OEM and are the property of their owners and are NOT used, or authorized for use, by ROTAMAC or its affiliates.

Neither ROTAMAC are affiliated with the Original Equipment Manufacturer "OEM" or licensed or authorized to produce parts for the OEM.



BÖRGER

Rotary Lobe Pumps - as individual as your application

At our head office in Borken Weseke - Germany, we design, produce and sell pumps, chopping units, separation technology, entry technology and agitator technology. Our core component is the patented Rotary Lobe Pump for pumping low to highly viscous and abrasive media.

Börger rotary lobe pumps convey different fluids, whether low or high viscosity, clean or containing solids, chemically aggressive or up to a temperature of 392 °F (200° C.) Due to the large selection of different materials, rotors and sealing systems, the pumps can be customized.

With our two series of BLUEline and ONIXline, the portfolio of 25 pump sizes with flow rates of 1 and 1,600 m³/h and pressure stabilities of up to 16 bar, Börger can offer the perfect pump for every single application.



BLUEline

Flow rates of 1 - 1,600 m³/h
Pressure up to 12 bar

Wide variety with 21 pump sizes in six series and the large selection of materials and rotors allow an individual design of the pump adapted to your application.



ONIXline

Flow rates of 1 - 135 m³/h
Pressure up to 16 bar

The large sealing chamber makes the use of different sealing systems possible. The pump casing is equipped with integrated porting for the seals. A sealing circulation system can be connected via this porting.



Variety of Rotors

Up to 8 different rotor geometries in various materials are available for each pump size.



High Quality Seals

Many different material combinations possible, single or double-acting, available as a cartridge unit.

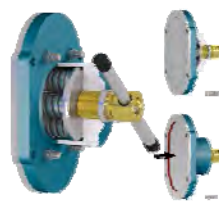

Overpressure Protection

Using a purely mechanical process, the pump is protected from uncontrolled pressure surges. Reversibility is maintained.



The Heatable Pump

The pump chamber can be heated by means of the heater jacket. This way, sensitive fluids are prevented from cooling down during the pumping process.



ROTARY LOBE PUMPS

Benefits of the Börger Rotary Lobe Pump

- Wide viscosity ranges demand customized solutions
- Flow volume independent of discharge pressure
- Self-priming and Run-dry capabilities
- Solids handling capabilities including abrasive and aggressive characteristics
- Reversible pumping operation, suitable for loading and un-loading application
- Maintenance in place, all replaceable parts can be easily installed and removed by without having to remove any pipe or drive systems

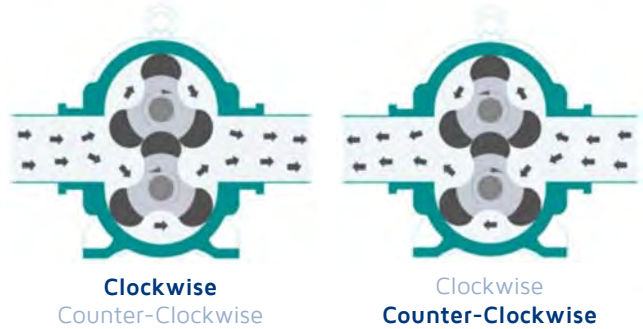

The unique MIP system for our pumps makes it easy.



Constructive Benefits

- The quick release cover, access to all wetted parts by simply loosening four ring nuts.
- The casing liners and casing protection plate protect the pump casing from wear.
- The liquid in the quench chamber cools and Lubricates the seals and protects the gear unit from pumped medium leaking in if the seal is defective.
- High quality and maintenance free carrier and timing gear.



BÖRGER.

Here's something for chopping!

Börger offers a choice of three different chopping units. The choice of chopping unit depends on the solids in the application. Our professional staff will be glad to assist you.



Multicrusher

Twin-shaft chopper with powerful suction function



Multichopper

Perforated disks chopper with multiple cuts per rotation



Rotorrake

Single coarse chopper with excellent hard material separation

Biogas / powerfeed entry technology



Efficient defibration of the biomass



Before

After

The Powerfeed is used for feeding solids into a flow pipeline in the fully enclosed system. Inside the Powerfeed the biomass is compressed and broken down very finely before it is fed into the system. This concept releases any trapped air from the biomass. The fine biomass particles have a large surface and ensure a higher gas yield.

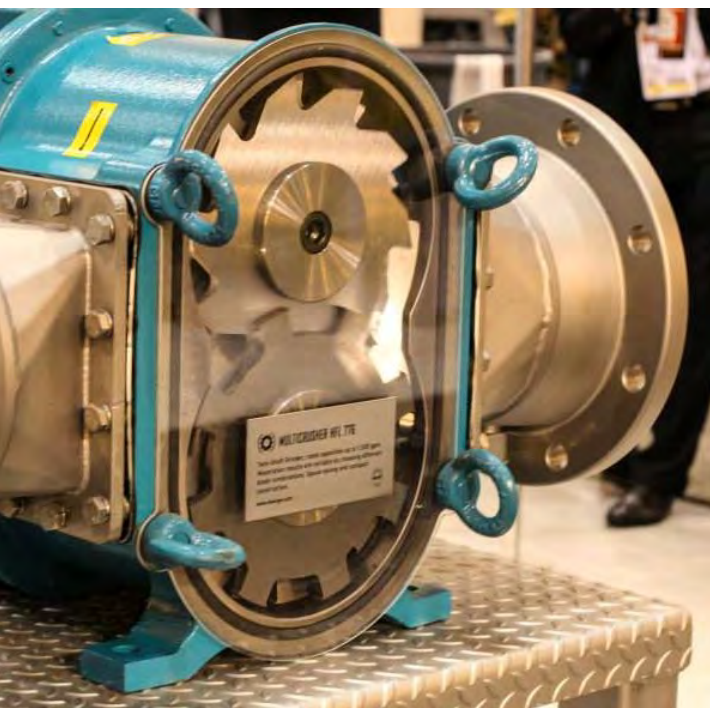

BIOGAS PLANT TECHNOLOGY

Bioselect – a separating system for liquids containing solids

Using a purely mechanical process, liquid parts are separated from solid parts in the medium. Maximum capacities of between 30 and 150 m³/h (130 and 660 gpm), the dry solids content is infinitely variable between 12 and 38 %.

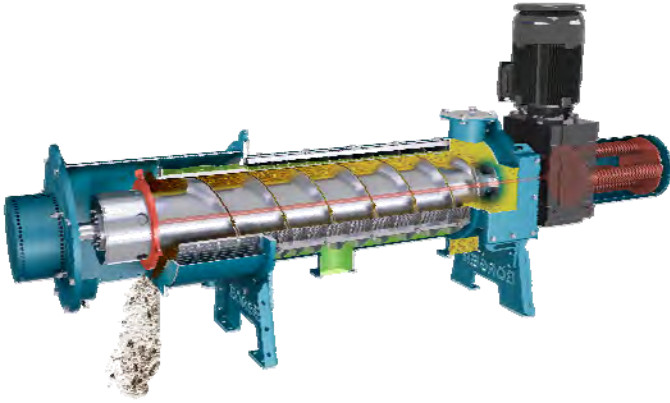

Benefits of the Börger bioselect

- Large capacities, low energy consumption
- No rubbing wear between the auger and screen, extremely long service life
- No risk of penetration – the rotating Multi Disc is always leakproof due to its design
- Everything from a single source - separator, pump, control unit and service

B-MX submersible mixer



The slim design and smooth surface of the device allows liquid to flow to the displacement blades without creating turbulence.

Stainless steel tanks



Capacities between 30 to 5,000 m³, The storage size can be increased without problems due to the segmented tank design, allow a customized.



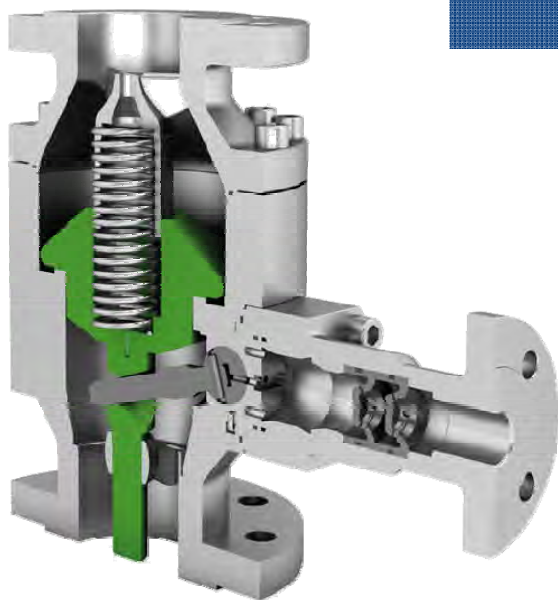

Pressure class
DIN 10 - 250 bar
ASME 150 - 2500 lbs

Size
25 - 500 mm
1" - 20"

SSV / SIP

Automatic Recirculation Valves with Bypass Throttle or Bypass Non-Return Valve

The automatic recirculation valve from our SSV and SIP series is a pump protection fitting which automatically protects centrifugal pumps, especially hot water pumps, against wear, complete breakdown and damage that can result from dry running or operating under low-load conditions.

As soon as the main flow falls below a certain value, the valve opens its bypass to the extent that the required pump minimum volume is discharged even if the main flow is zero. The pressure in the minimum volume is reduced via an integrated throttle line with a bypass non-return valve. If a non-return valve in the bypass is not required, the series SSV 10-12 is to be applied.

Trimod^BBesta

Besta AG was founded in 1966 as a 100% subsidiary of Bachofen Holding AG in Uster. As of October 2015 the company was merged with the Bachofen Automation business unit.

The Trimod^BBesta Level, Flow, Pressure and Temperature products are developed and can be used for applications from -196°C to +400°C, from vacuum to 320 bar process pressure and low density applications.

Made possible by the 3 - modular concept :

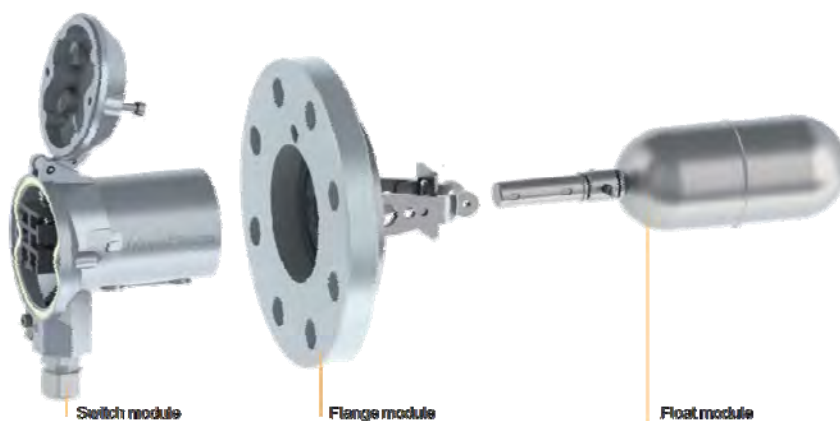

AUTOMATIC RECIRCULATION [ARC VALVES]

SHP

Automatic Recirculation Valves for High Pressure Applications

The SHP series automatic recirculation valve protects pumps and equipment from damage that can occur due to the flow rate falling below the permissible minimum. The innovative design ensures that pumps and equipment are reliably protected, even in situations involving highly fluctuating pump loads and long periods of operation under extreme partial load conditions. This is achieved by using a special fully automatic minimum flow control system that ensures the release of a modulating adaptive minimum flow. In addition, the wear-intensive extreme partial load range is deliberately overridden. The shut-off and pressure reduction functions are both functionally and physically separate from each other.

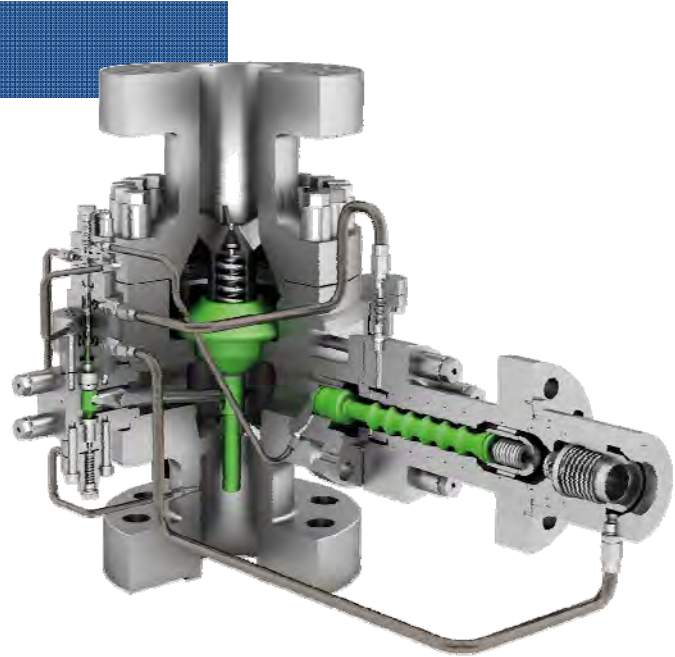

Pressure class
DIN 250 - 400 bar
ASME 1500 - 2500 lbs

Size
100 - 300 mm
4" - 12"

LEVEL CONTROL



Level Switches

Trimod Besta level switches feature unique robustness. They are easily handled and quickly connected. High temperature up to 400°C, Low temperature down to -196°C. Flameproof range for Zone 1 or Zone 0 and the plastic range is also available.



Level Indicators

Magnetic level indicators combine up to three functions in a single unit: display, switch and transmitter. The display, which can be read from great distances, works without energy.



Level Sensors

These robust and highly reliable level sensors use the optical principle, capacitive or frequency sweep technology. Easy to use, easy to install and maintenance free.



Level Transmitters

Level transmitter made from stainless steel or Polypropylene with a 4 – 20 mA output signal or 3-wire resistance signal. They work reliably and safely, even under harsh operating conditions.

Valve Experience. Made in Germany.

Whether lift check valves, dual plate check valves, swing check valves, high pressure valves, tank bottom valves or sampling systems: RITAG enjoys an excellent reputation worldwide as a specialist in industrial valves. The valves are produced in Germany and installed world wide. Our team of dedicated professionals are the core of our engineering competence and they like to share their knowledge and know-how with our industry customers.

Our valve manufacturing plant is equipped with modern tools such as 3D-CAD, FEM, CFD and CAM. All production levels are linked in our IT-network. Stable processes and our electronic workflow guarantee fast and precise results.

We guarantee that our industrial valves will arrive at the right place and at the right time. Our logistics operation takes pride in meeting deadlines from order placement through production and on to a punctual delivery.

TANK BOTTOM , SAMPLING VALVES



**Lift Check [Disc Check]
DIN PN6 - 160**

Wafer-type non-return (check) valve for sandwiching between flanges. It can be installed in any position and is suitable for liquid, gas and steam.



**Lift Check [Disc Check]
ANSI Class 150 - 2500**

Wafer-type check valve for fitting between flange acc. to ASME B16.5. Face to face dimension acc. to EN558. Large selection of materials for any requirement.



Tank Bottom Valves

Trouble-free, clean, secure and efficient tank drainage. They are used wherever drainage through a normal on/off valve or a ball valve cannot be done.



Sampling Valves

The RITAG cone and piston valves are exceptionally well suited for sampling from containers. Sampling also under pressure or vacuum conditions.



WAFER TYPE CHECK VALVES



Swing Check , ANSI Class 150, DIN PN6 - 40

Wafer-type check valve with short overall length. The low weight of the equipment is beneficial for transportation, storage and installation.



Dual Plate Check Wafer Type

Type ZRD dual plate check valve is available in a broad spectrum of nominal diameters DN50 to DN1400 and nominal pressures to PN160 / Class 2500.



Dual Plate Check Lug Type

The check valve is fixed between two flanges using through bolts for solid lug or provided with threaded holes on both sides for Tapped Lug.



Dual Plate Check Flange Type

The check valve is fitted with connection flanges on both sides. The shortness of the bolts means the temperature effect on them is low.



EPOS® Sampling Systems

The RITAG EPOS® sampling systems are of a modular design and offer a wide range of combination options for all requirements.



Clean Service Check CIP - Clean in Place

RITAG HYPOS 100 check valve with EHEDG certificate verifies the proper CIP functionality of the valve. The SR 93.16 is an economically priced alternative.



Clean Service Tank Bottom Valves

The dead space free and mostly crevice-free valve permit the easy cleanability of the RITAG tank bottom valve. The welded design make the system very flexible.



Clean Service Sampling Valves

Their distinguishing characteristics are no-dead-space and nearly no gaps, which makes them especially secure and reliable during cleaning.

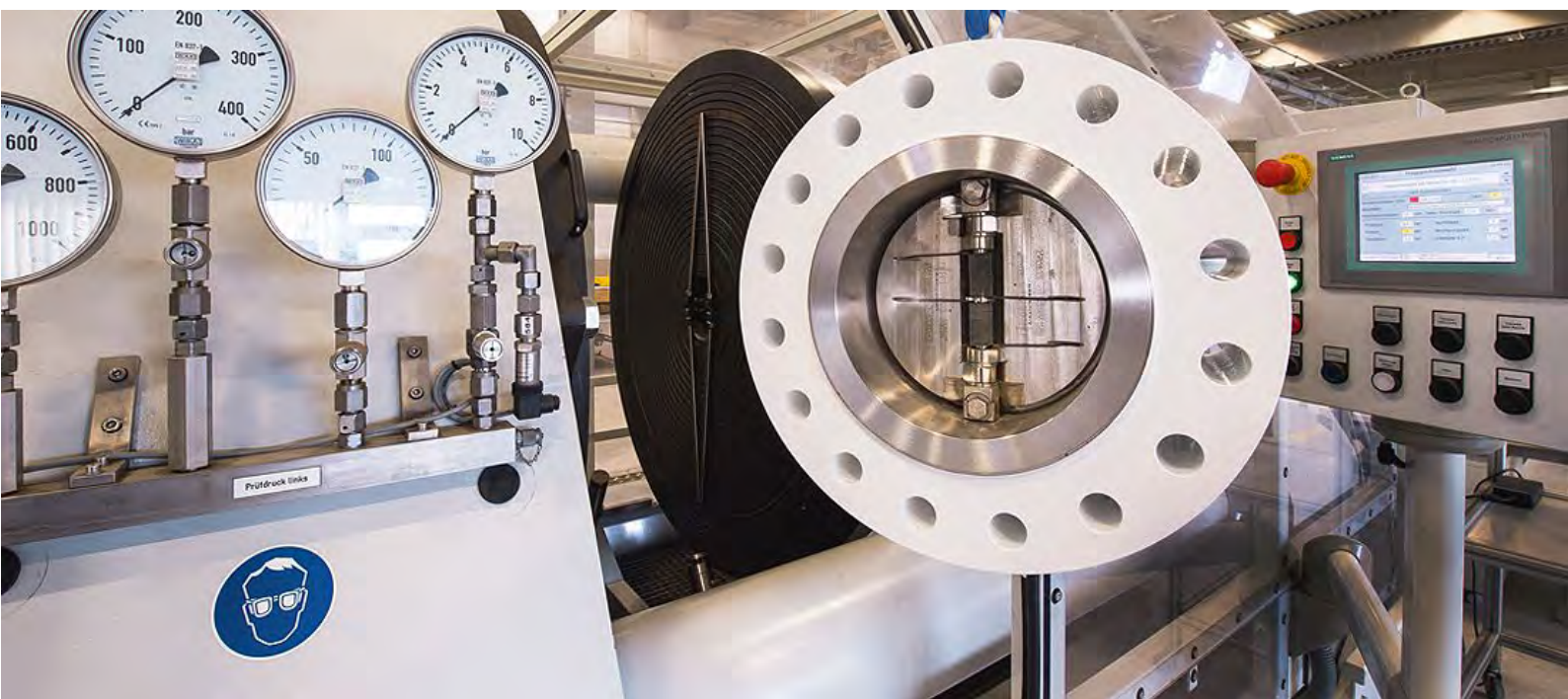

Energy Technology Co.,Ltd.

436 Soi On-Nuch 39, Sukhumvit Rd.,
Suanluang, Bangkok 10250

Tel : 66-2721-3860 (Auto 20 Lines)
Fax : 66-2721-3869
Email : admin@energytechnology.co.th
 : sales@energytechnology.co.th
Website : www.energytechnology.co.th

