

GESTRA Steam Systems

Product Range A4

Valve Selection Cooling-Water Control Valves Gestramat CW 41, CW 41/4 PN 16, DN 25 – 100 mm (1 – 4")

CW 41 CW 41/4

1. Selection of Valve Type in accordance with Cooling Medium

Cooling medium	Valve type
Industrial cooling water	CW 41
Ammoniacal water, salt water, chlorinated hydrocarbons	CW 41/4

2. Selection of Thermostat / Cone Combination Simplified method

In practice – for existing plants – the thermostat/cone combination can, as a rule, be selected against the desired cooling-water outlet temperature.

Desired cooling-water outlet temperature	Thermostat/cone combination
20 to 60 °C (68 to 140 °F)	wr
50 to 100 °C (122 to 212 °F)	nr
-32 to +30 °C (-25 to +86 °F)	kr

Calculation method see opposite (2.1).

3. Nominal Size (DN)

The size of the cooling-water control valve should, where possible, correspond to that of the adjacent pipework. When applying the simplified selection method for the valve/cone combination, usually the pipe size can also be taken as valve size.

The following sizes are available:
DN 25, 40, 50, 80, 100 mm (1, 1½, 2, 3, 4").

4. Connections

Flanges to DIN 2533 (BS 4504) PN 16.

On request at extra cost, flanges drilled to ANSI 125/150.

2.1 Selection of Thermostat / Cone Combination by means of Calculation

With this calculation the thermostat/cone combination is determined in accordance with full operational data.

Calculation method

- a) Actual cooling-water outlet temperature in summer?

$$t_o = \dots\dots\dots \text{°C}$$

Cooling-water inlet temperature in summer?

$$t_i = \dots\dots\dots \text{°C}$$

Maximum admissible cooling-water outlet temperature?

$$t_{cw} = \dots\dots\dots \text{°C}$$

Hence:

Actual temperature difference $\Delta t_1 = t_o - t_i = \dots\dots\dots \text{K}$
Desired temperature difference $\Delta t_2 = t_{cw} - t_i = \dots\dots\dots \text{K}$

- b) Service pressure in the cooling-water feed line?

$$p_1 = \dots\dots\dots \text{ barg}$$

Back pressure in the cooling-water return line?

$$p_2 = \dots\dots\dots \text{ bar}$$

Level difference between the measuring points for service pressure and back pressure?

$$\text{Height of fall } h_1 = \dots\dots \text{ m} \cong p_{h1} \dots\dots \text{ bar}$$

or

$$\text{Height of lift } h_2 = \dots\dots \text{ m} \cong p_{h2} \dots\dots \text{ bar}$$

Calculate the differential pressure as follows:

$\Delta p = p_1 + p_{h1} = \dots\dots\dots \text{ bar}$
or
$\Delta p = p_1 - p_{h2} = \dots\dots\dots \text{ bar}$

- c) Actual uncontrolled cooling-water flowrate of plant?

$$\dot{V} = \dots\dots\dots \text{ m}^3/\text{h}$$

or

maximum amount of heat to be evacuated?

$$Q = \dots\dots\dots \text{ kJ/h}$$

Calculation of k_v value:

$k_v = \frac{\dot{V}}{\sqrt{\Delta p \left[\left(\frac{\Delta t_2}{\Delta t_1} \right)^2 - 1 \right]}} = \dots\dots\dots \text{ m}^3/\text{h}$
or
$k_v = \frac{Q}{4.2 \cdot 10^3 \sqrt{\Delta p (\Delta t_2^2 - 9)}} = \dots\dots\dots \text{ m}^3/\text{h}$

- d) With the aid of Δt_2 , k_v , t_{cw} and the nominal size (DN) the code letters for the thermostat/cone combination can be found in the charts on the back.

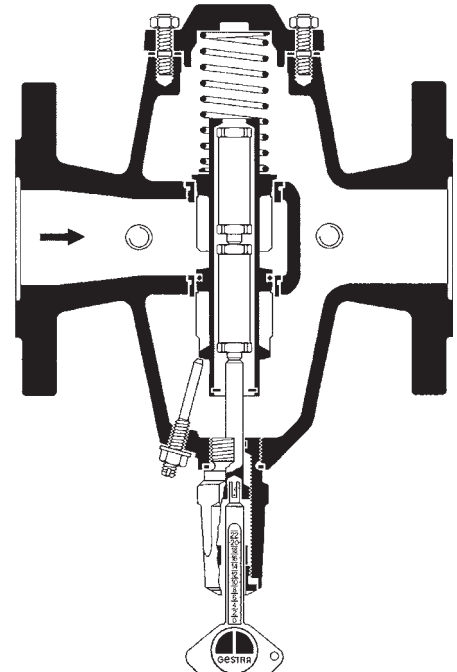

CW 41
DN 40/50

Valve Selection
Cooling-Water Control Valves
Gestramat CW 41, CW 41/4
PN 16, DN 25 – 100 mm (1 – 4")

Charts for the determination of the code letters for the thermostat / cone combination

Example 1

The code letters for a cooling-water control valve CW 41 are required, operating data as follows:

- $\Delta t_2 = 14 \text{ K}$
- $k_v = 15 \text{ m}^3/\text{h}$
- $t_{\text{CW}} = 40 \text{ }^\circ\text{C}$
- Nominal size DN 50 mm

Solution

The point of intersection between $\Delta t_2 = 14$ and $k_v = 15$ in the chart for DN 40, 50 mm falls into the common range for the code letters ws, ns, ks.

According to the temperature:

- | | |
|----|---|
| ws | for $t_{\text{CW}} = 20$ to $60 \text{ }^\circ\text{C}$ |
| ns | for $t_{\text{CW}} = 50$ to $100 \text{ }^\circ\text{C}$ |
| ks | for $t_{\text{CW}} = -32$ to $+30 \text{ }^\circ\text{C}$ |

As $t_{\text{CW}} = 40 \text{ }^\circ\text{C}$, choose code letters ws in this case.

Example 2

If the point of intersection between Δt_2 and k_v falls into the range wr, nr, kr, choose:

- | | |
|----|---|
| wr | for $t_{\text{CW}} = 20$ to $60 \text{ }^\circ\text{C}$ |
| nr | for $t_{\text{CW}} = 50$ to $100 \text{ }^\circ\text{C}$ |
| kr | for $t_{\text{CW}} = -32$ to $+30 \text{ }^\circ\text{C}$ |

Enquiry Specification

GESTRA cooling-water control valve Gestramat CW 41 or CW 41/4. With solid-state thermostat(s), double-seat valve cone, pressure gauge, and thermometer.

Order Specifications

Valve type, thermostat/cone combination, nominal size (DN), connections (see "Valve Selection").

Type of cooling agent, inlet pressure, back pressure, uncontrolled coolant flowrate or heat amount to be discharged.

Note concerning valve cone selection:

If the nominal size of the valve has not yet been determined (see also point 3) the point of intersection $\Delta t_2/k_v$ can usually be found in several charts.

In this case choose the valve cone with the slightest bleed flow (see k_{v0} value under "Technical Data" in data sheet CW 41, CW 41/4).

Supply in accordance with our general terms of business.

DN 25 mm (1")

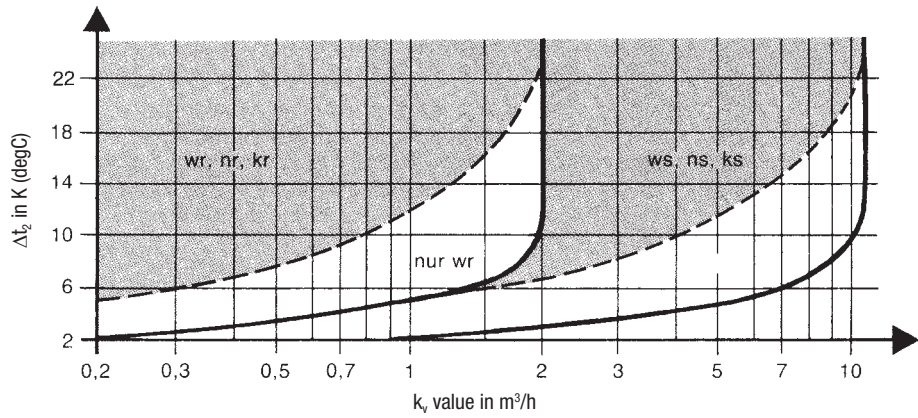

DN 40, 50 mm (1½, 2")

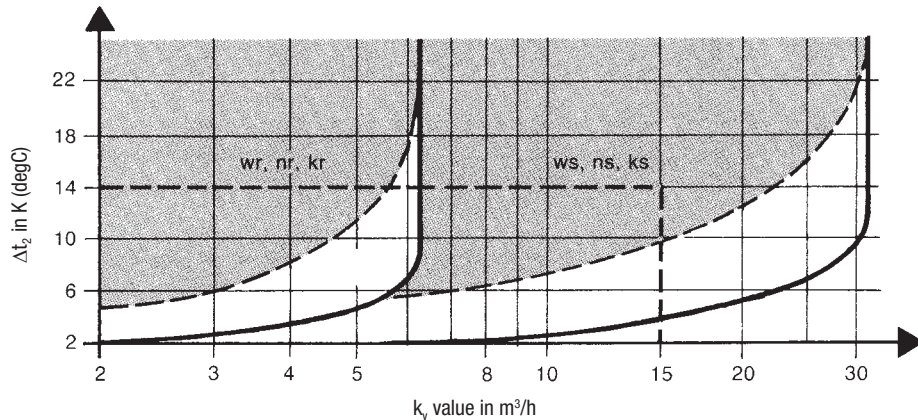

DN 80, 100 mm (3, 4")

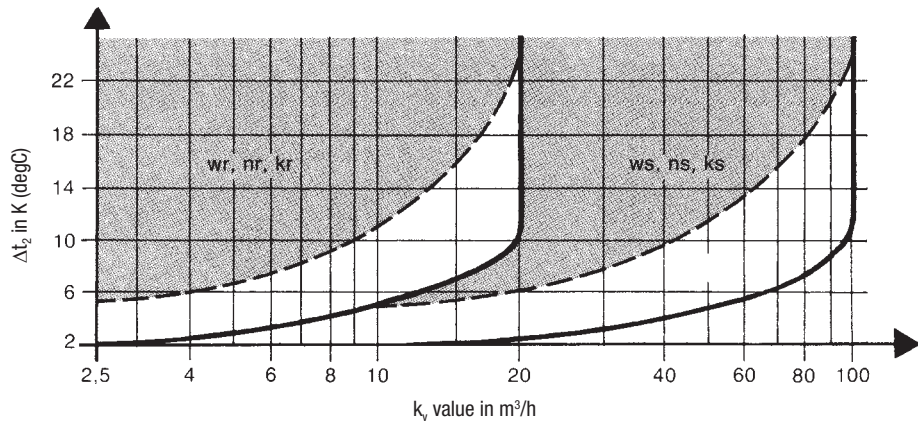

GESTRA AG

P. O. Box 10 54 60, D-28054 Bremen
 Münchener Str. 77, D-28215 Bremen
 Telephone +49 (0) 421 35 03-0, Fax +49 (0) 421 35 03-393
 E-Mail gestra.ag@flowserve.com, Internet www.gestra.de



Distributor : Energy Technology Co., Ltd.

Tel.: +66 2 721 3860 - Fax.: +66 2 721 3869 - E-mail: sales@energytechnology.co.th - http:// www.energytechnology.co.th