

GESTRA Steam Systems

High-Level Alarm
With CAN Bus, CANopen Protocol
NRG 16-41, NRG 17-41, NRG 19-41

Product Range B

NRG 16-41
NRG 17-41
NRG 19-41

System Description

The level electrode operation is based on the conductive measuring principle. The NRG 1...-41 is designed for signalling the max. liquid level in electrically conductive liquids.

■ One liquid level with **one** switchpoint

The NRG 1...-41 is to be used in conjunction with the switching controller NRS 1-41 and further system components. The NRG 1...-41 in conjunction with its associated control equipment constitutes a water level limiter with periodic self-testing routine (SMART function) in accordance with TRD 604, sheet 1 and 2 and EN regulations. The level data are transferred from the electrode NRG 1...-41 to the control unit via a CAN bus using the CANopen protocol.

Function

The conductivity of the liquid is used to signal the liquid level. Some liquids are conductive, which means that they allow an electric current to flow through them. For the safe functioning of this device a minimum conductivity of the liquid to be measured is required.

The conductivity measurement method can detect two conditions: electrode rod submerged or exposed, meaning switchpoint reached (or exceeded) or not yet reached. Before installation, the length of the electrode rod must be cut to the required switching level, e. g. for "Pump OFF" or "Control valve CLOSED" or, in case of economiser and air heaters that are installed close to the steam-generating unit and exposed to a risk, "Firing/Burner OFF".

An additional electrode fully integrated in the system automatically monitors the electrical resistance path between earth and measuring electrode. As soon as the actual value falls below the admissible resistance value the protection circuit is interrupted and cuts off the pump or heat supply to the boiler.

Function – continued –

At regular intervals the level electrode NRG 1...-41 sends a data telegram to the switching controller NRS 1-41. The data are transferred via a CAN bus to DIN ISO 11898 using the CANopen protocol.

Design

NRG 1...-41: Screwed 3/4", EN ISO 228-1

Technical Data

Type Approval

TÜV · SWB / SHWS · XX-403
EG BAF-MUC 02 02 103881 002

Service pressure

NRG 16-41: 32 bar g at 238 °C
NRG 17-41: 46 bar g at 260 °C
NRG 19-41: 100 bar g at 311 °C

Connection

Screwed 3/4", EN ISO 228-1

Materials

Terminal box: Die cast aluminium 3.2161 (G AISi8Cu3)
Body: S. S. 1.4571 (X6CrNiMoTi17-12-2)
Measuring electrode: S. S. 1.4401 (X5CrNiMo17-12-2)
Electrode insulation: PEEK

Lengths supplied

500 mm
1000 mm
1500 mm

Sensitivity of response

> 0.5 µS/cm at 25 °C.

Supply voltage

18–36 V DC (coming from NRS 1-41)

Current consumption

35 mA

P.T.O.

Important Note

NRS, NRR, LRR, TRS, URB 1

To wire the equipment, screened multi-core twisted-pair control cable **must** be used for the bus line, e. g. UNITRONIC® BUS CAN 2 x 2 x ... mm² or RE-2YCYV-fl 2 x 2 x ... mm².

Control cable assemblies (2 x 2 x 0.32 mm² cable with plug and connector) of various lengths are available as add-on equipment.

NRG, LRG, EF, URZ, TRV, URB 2

The equipment is fitted with sensor plug-in connectors (5 poles, A-coded). For connecting the bus devices control cable assemblies (with plug and connector) of various lengths are available as add-on equipment.

Note that the recommended control cables are not UV-resistant and must be protected by a UV-resistant plastic tube or cable duct if the equipment is installed outdoors (except for URB 2).

The baud rate (data transfer rate) dictates the cable length and size between the bus nodes. The total power consumption must also be taken into consideration when selecting the conductor size. The total power consumption is obtained from the number of bus nodes. If the cable length between the steam boiler and the control cabinet exceeds 15 m, we recommend that you fit a branching box that is resistant to electromagnetic interference (stock code 1501214) and use a control cable with a larger conductor size for the distance to the control cabinet.

S 8	S 9	S 10	Baud rate	Cable length	Number of pairs and conductor size [mm ²]
OFF	ON	OFF	250 kBit/s	125 m	2 x 2 x 0.32
Factory setting					
ON	ON	OFF	125 kBit/s	250 m	2 x 2 x 0.5
OFF	OFF	ON	100 kBit/s	335 m	2 x 2 x 0.75
ON	OFF	ON	50 kBit/s	500 m	on request, depending on bus configuration
OFF	ON	ON	20 kBit/s	1000 m	
ON	ON	ON	10 kBit/s	1000 m	

Set baud rate via code switch. Make sure that all bus nodes feature the same settings.

UNITRONIC® is a registered trademark of LAPP Kabelwerke GmbH, Stuttgart.

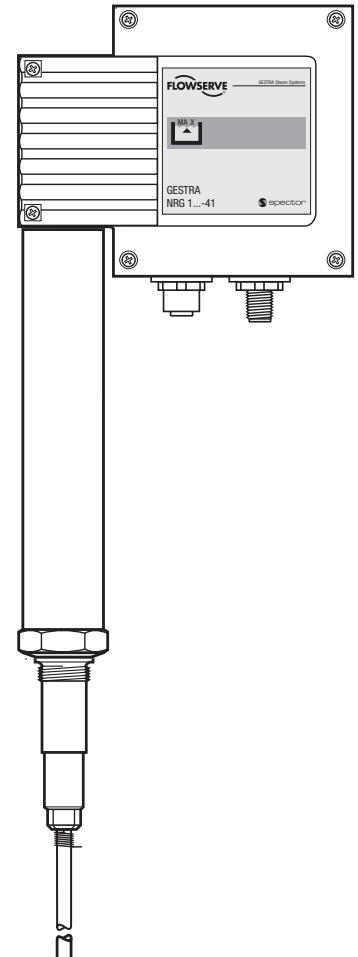

Wiring Diagram

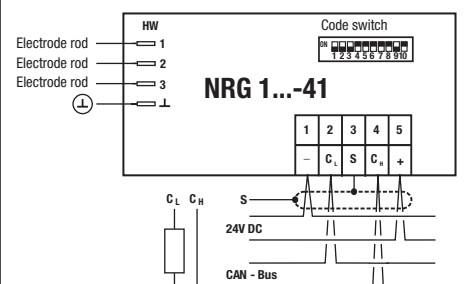

Terminating resistor 120 Ω,
Multi-paired cable.

e.g. UNITRONIC®
BUS CAN 2 x 2 x ...²

High-Level Alarm
With CAN Bus, CANopen Protocol
NRG 16-41, NRG 17-41, NRG 19-41

Technical Data – continued –

Fuse

Electronic thermal fuse $T_{max} = 85\text{ °C}$

Hysteresis

-2 K

Electrode voltage

$2 V_{SS}$

Data exchange

CAN bus to DIN ISO 11898, CANopen Protocol

Indicators and adjustors

One 10-pole code switch for node ID and baud rate settings

Two LEDs "PROGRAM RUNNING"

Two LEDs "CAN BUS COMMUNICATION"

Electric connection

M 12 sensor connector, 5 poles, A-coded,

M 12 sensor jack, 5 poles, A-coded

Protection

IP 65 to DIN EN 60529

Max. admissible ambient temperature

70 °C

Weight

Approx. 2.5 kg

Order and Enquiry Specification

GESTRA Level electrode NRG 1...-41

Associated Controller

■ Switching controller NRS 1-41

Ancillary Unit

■ Operating terminal & visual display unit URB 1, URB 2

Key

- ① Flange PN 40, DN 50, DIN 2527
Flange PN 40, DN 100, DIN 2527
- ② For the approval of the boiler standpipe with connecting flange the relevant regulations must be considered.
- ③ Vent hole
- ④ Electrode rod $d = 8\text{ mm}$
- ⑤ Protection tube $\geq\text{ DN }100$
- ⑥ High water level (HW)
- ⑦ Reducer K-88.9 x 3.2 - 42.4 x 2.6 W
- ⑧ Electrode distance
- ⑨ Lengths of electrode tips
500 mm
1000 mm
1500 mm
- ⑩ Low water level (LW)

ATEX (Atmosphère Explosible)

According to the European Directive 94/9/EC the equipment must **not** be used in explosion-risk areas.

Supply in accordance with our general terms of business.

Dimensions

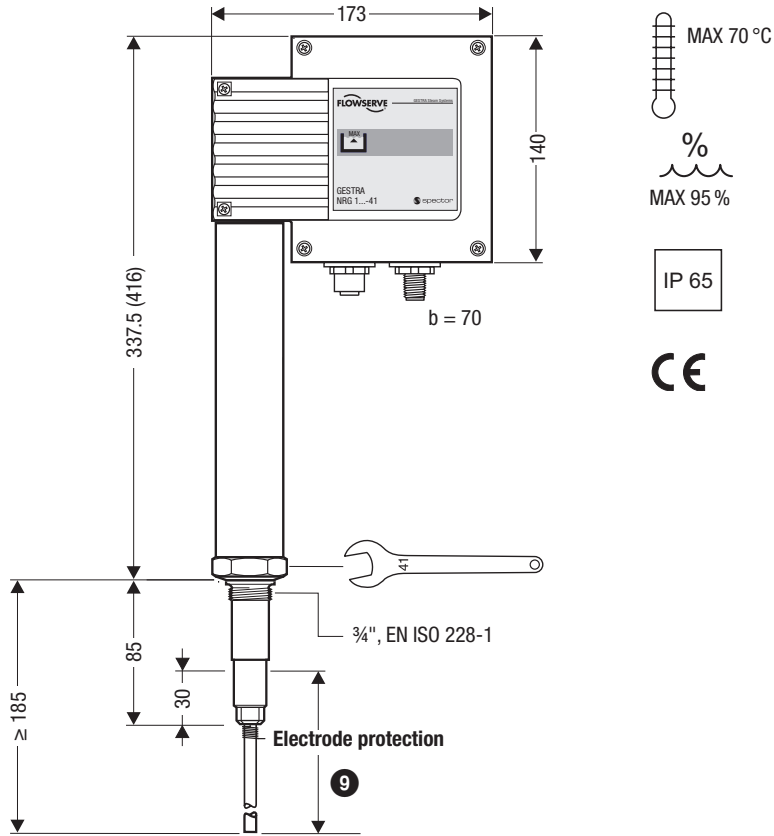

Fig. 1 NRG 16-41, NRG 17-41

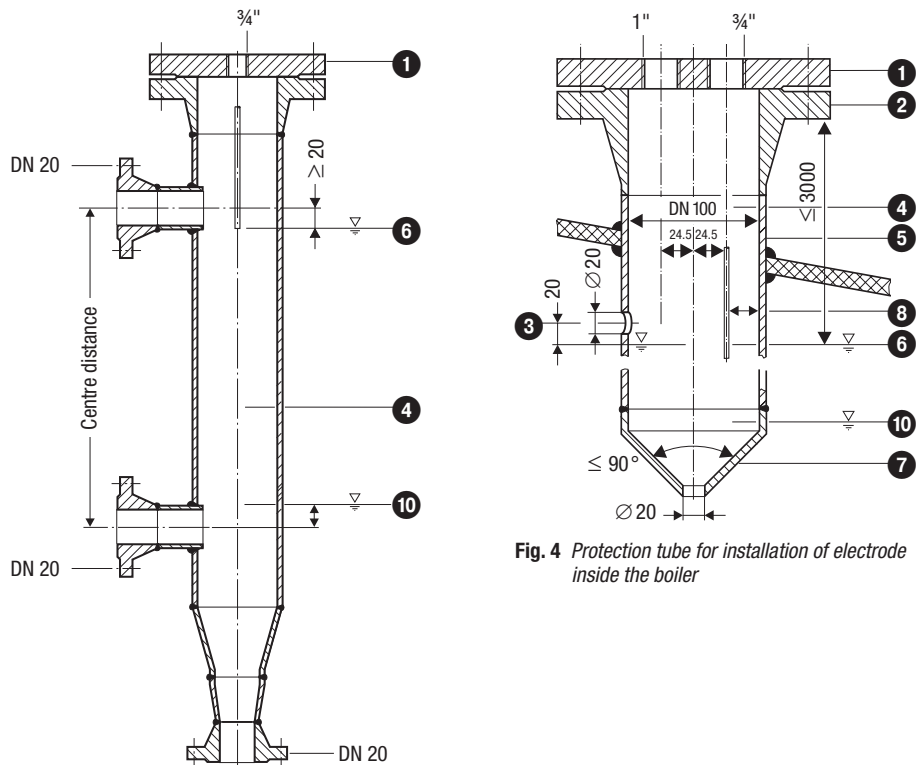

Fig. 2 External measuring pot

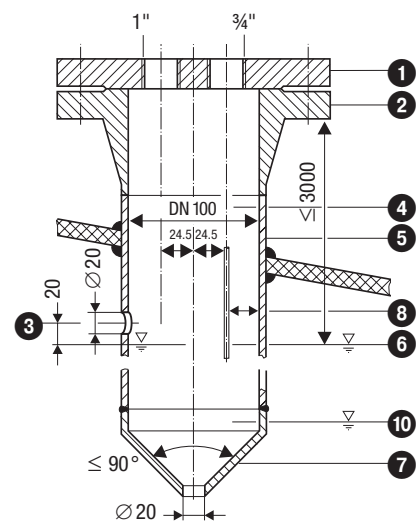

Fig. 4 Protection tube for installation of electrode inside the boiler

GESTRA AG

P. O. Box 10 54 60, D-28054 Bremen
Münchener Str. 77, D-28215 Bremen
Telephone 0049 (0) 421 35 03 -0, Fax 0049 (0) 421 35 03 -393
E-mail gestra.ag@flowsolve.com, Internet www.gestra.de



Distributor : Energy Technology Co., Ltd.

Tel.: +66 2 721 3860 - Fax.: +66 2 721 3869 - E-mail: sales@energytechnology.co.th - http:// www.energytechnology.co.th